



Installation and Operating Instructions

Evershine TLC4000/5000/6000/8000/10000 Solar Inverters

zeversolar

Table of Contents

1 About this manual.....	1
1.1 Validity	1
1.2 Target group	1
1.3 Symbols used in this manual	2
2 Safety	3
2.1 Intended use.....	3
2.2 Safety standards	3
2.3 Important safety information	4
2.4 Symbols on the type label	5
2.5 Basic safety protection	6
3 Unpacking	7
3.1 Scope of delivery	7
3.2 Check for transport damage.....	7
4 Mounting.....	8
4.1 Ambient conditions.....	8
4.2 Selecting the mounting location	10
4.3 Mounting the inverter with the wall bracket	11
5 Electrical connection	13
5.1 Safety.....	13
5.2 System layout of units without integrated DC-switch.....	14
5.3 Overview of the connection area	15
5.4 AC Connection.....	16
5.4.1 Conditions for the AC connection.....	16

5.4.2 Grid connection.....	17
5.4.3 Second protective grounding connection	19
5.4.4 Residual current protection	20
5.4.5 Overvoltage category	20
5.4.6 AC circuit breaker	21
5.5 DC connection	22
5.5.1 Requirements for the DC connetion.....	22
5.5.2 Assembling the DC connectors.....	23
5.5.3 Disassembling the DC connectors	25
5.5.4 Connecting the PV Array	26
6 Communication	28
6.1 System monitoring via RS485.....	28
6.2 System monitoring via Ethernet.....	32
6.3 System monitoring via WiFi.....	33
6.4 Communication with a third party monitoring device	33
6.5 Updating the firmware via USB	33
7 Commissioning	34
7.1 Electrical check.....	34
7.2 Mechanical check	35
7.3 Start-up	35
8 Disconnecting the inverter from voltage sources.....	36
9 Operating.....	37
9.1 Overview of the control panel.....	37
9.2 LED indicators.....	38
9.3 Display messages.....	39
9.4 Display	41

9.4.1 Overview of menu structure	41
9.4.2 Initial page.....	42
9.4.3 Unlock page.....	42
9.4.4 Home page.....	42
9.4.5 Operation information	43
9.4.6 Main menu.....	44
9.4.7 Statistics	44
9.4.8 Event log.....	45
9.4.9 Data&Time Setting	45
9.4.10 Language setting.....	46
9.4.11 Contrast setting.....	46
9.4.12 Safety regulations setting.....	47
9.4.13 Overload setting	48
9.4.14 Active power control	48
9.4.15 Reactive power control	49
9.4.16 PV Mode setting.....	50
9.4.17 EEG setting	50
9.4.18 Communication setting.....	51
9.4.19 Device information	51
9.4.20 Clear history data	52
10 Technical data.....	53
10.1 DC input data	53
10.2 AC output data	54
10.3 General data	56
10.4 Safety regulations	57
10.5 Efficiency.....	58
10.6 Power reduction.....	61
11 Troubleshooting	64
12 Maintenance	66

12.1 Cleaning the contacts of the DC-switch.....	66
12.2 Cleaning the heat sink	66
13 Recycling and disposal	67
14 Warranty.....	67
15 Contact	68

1 About this manual

General Notes

Evershine is a transformerless solar inverter with two MPP trackers. It converts the direct current (DC) from the PV arrays to grid-compliant alternating current (AC) and feeds it into the grid.

1.1 Validity

This manual describes the mounting, installation, commissioning and maintenance of the following Zeversolar inverters:

- Evershine TLC4000
- Evershine TLC5000
- Evershine TLC6000
- Evershine TLC8000
- Evershine TLC10000

Observe all documentation that accompanies the inverter. Keep them in a convenient place and available at all times.

1.2 Target group

This document is intended for qualified persons and end users. Only qualified persons are allowed to perform the activities marked in this document with a warning symbol. Tasks that do not require any particular qualification are not marked and can also be performed by end users. Qualified persons must have the following skills:

- Knowledge of how an inverter works and is operated
- Training in how to deal with the dangers and risks associated with installing and using electrical devices and installations
- Training in the installation and commissioning of electrical devices and installations
- Knowledge of the applicable standards and directives
- Knowledge of and compliance with this document and all safety information.

1.3 Symbols used in this manual

The following safety precautions and general information are used in this manual:

DANGER

DANGER indicates a hazardous situation which, if not be avoided, will result in death or serious injury.

WARNING

WARNING indicates a hazardous situation which, if not be avoided, can result in death or serious injury.

CAUTION

CAUTION indicates a hazardous situation which, if not be avoided, can result in minor or moderate injury.

NOTICE

NOTICE indicates a situation which, if not be avoided, can result in property damage.



INFORMATION provides tips which are valuable for the optimal installation and operation of the inverter.

2 Safety

2.1 Intended use

1. Evershine converts the direct current from the PV arrays into grid-compliant alternating current.
2. Evershine is suitable for indoor and outdoor use.
3. Evershine must only be operated with PV arrays (PV modules and cabling) of protection class II, in accordance with IEC 61730, application class A.
Do not connect any sources of energy other than PV modules to Evershine.
4. PV modules with a high capacity to ground must be used if their coupling capacity does not exceed 1.0 μ F.
5. When the PV modules are exposed to light, a DC voltage is supplied to this device.
6. When designing the PV power plants, ensure that the values comply with the permitted operating range of all components at all times. The free design program "Zeverplan" (<http://www.zeverplan.com>) will assist you.

2.2 Safety standards

Evershine complies with the EU Low Voltage Directive 2006/95/EC and the EMC Directive 2004/108/EC. Evershine also complies with the requirements for safety and EMC in Australia and New Zealand market.

Evershine labels with the CE and RCM marks. For more detail information about certificates in other countries and regions, please visit website (<http://www.zeversolar.com>).

2.3 Important safety information

DANGER

- All work on the inverter must only be carried out by qualified personnel who have read and fully understood all safety information contained in this manual.
- Children must be supervised to ensure that they do not play with this device.

WARNING

Risk of injury due to electric shock and fire caused by high leakage current

- The inverter must be reliably grounded in order to protect property and personal safety.

CAUTION

Risk of injury due to hot heat sink

- The heat sink may get hot during operation. Do not touch!

CAUTION

Possible damage to health as a result of the effects of electromagnetic radiation









- Please maintain a distance of at least 20cm from the inverter when it is in operation.

NOTICE

Grounding the PV modules frame

- Comply with local regulations for grounding the PV array. We suggest the frames of PV modules must be reliably grounded.
- Do not ground any of the terminals of the PV strings.

2.4 Symbols on the type label

Icon	Explanation
	Risk of danger, warning and caution Safety information important for human safety. Failure to observe the safety information in this manual may result in injury or death.
	Danger to life due to electric shock The product operates at high voltages. Prior to performing any work on the product, disconnect the product from voltage sources. All work on the product must be carried out by electrically qualified persons only.
	Risk of burns due to hot surfaces The product can get hot during operation. Avoid contact during operation. Allow the product to cool down sufficiently before carrying out any work.
	WEEE designation Do not dispose of the product together with the household waste but in accordance with the disposal regulations for electronic waste applicable at the installation site.
	CE marking The product complies with the requirements of the applicable EU directives.
	Certified safety The product is TUV-tested and complies with the requirements of the EU Equipment and Product Safety Act.
	RCM The product complies with the requirements of the applicable Australian low voltage and electromagnetic compatibility standards.
	Capacitors discharge Danger to life due to high voltages in the inverter, observe the waiting time of five minutes. Prior to performing any work on the inverter, disconnect it from all voltage sources as described in chapter 8.
	Observe the documentation Observe all documentation supplied with the product.

2.5 Basic safety protection

We provide the following safety protection:

1. Overvoltage, undervoltage protection.
2. Overfrequency, underfrequency protection.
3. Overtemperature monitoring.
4. Residual current monitoring.
5. Isolation fault detection.
6. Anti islanding protection.
7. DC Injection monitoring.

3 Unpacking

3.1 Scope of delivery

Object	Description	Quantity
A	Inverter	1
B	Wall bracket	1
C	Mounting accessory kit: M5×12 pan head screw (2×) wall anchor and hexagon head screw (4×), terminal lug (1×), ground washer (1×)	1
D	DC connector	2/3 ⁽¹⁾
E	AC connection plug	1
F	RJ45 plug	2
G	Sealing plug	2/1 ⁽²⁾
H	WiFi antenna (optional)	1
I	Documentation	1

(1) 2 pairs for TLC4000~TLC6000, and 3 pairs for TLC8000~TLC10000.

(2) 1 pcs for the inverter with WIFI module.



A

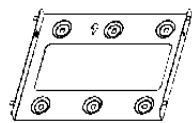

B



C



D



E



F



G



H

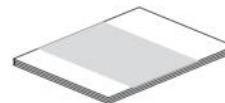

I

Please carefully check all of the components in the carton. If anything is missing, contact your dealer at once.

3.2 Check for transport damage

Thoroughly inspect the packaging upon delivery. If you detect any damage to the packaging which indicates the inverter may have been damaged, inform the responsible shipping company immediately. We will be glad to assist you if required.

4 Mounting

4.1 Ambient conditions

1. Be sure that the inverter is mounted out of the reach of children.
2. Mount the inverter in areas where it cannot be touched inadvertently.
3. Ensure good access to the inverter for installation and possible service.
4. The ambient temperature should be below 40°C to ensure optimal operation.
5. Observe the minimum clearances to walls, other inverters, or objects as follows to ensure sufficient heat dissipation.

Direction	Min. clearance (mm)
above	300
below	500
sides	200

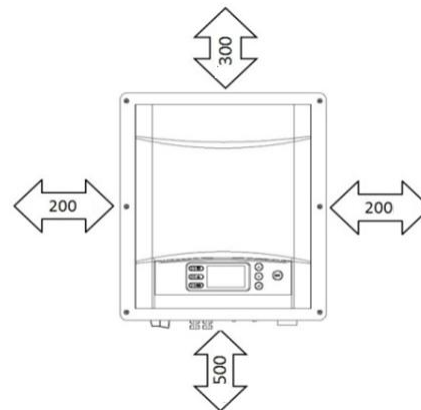

Clearances for one inverter

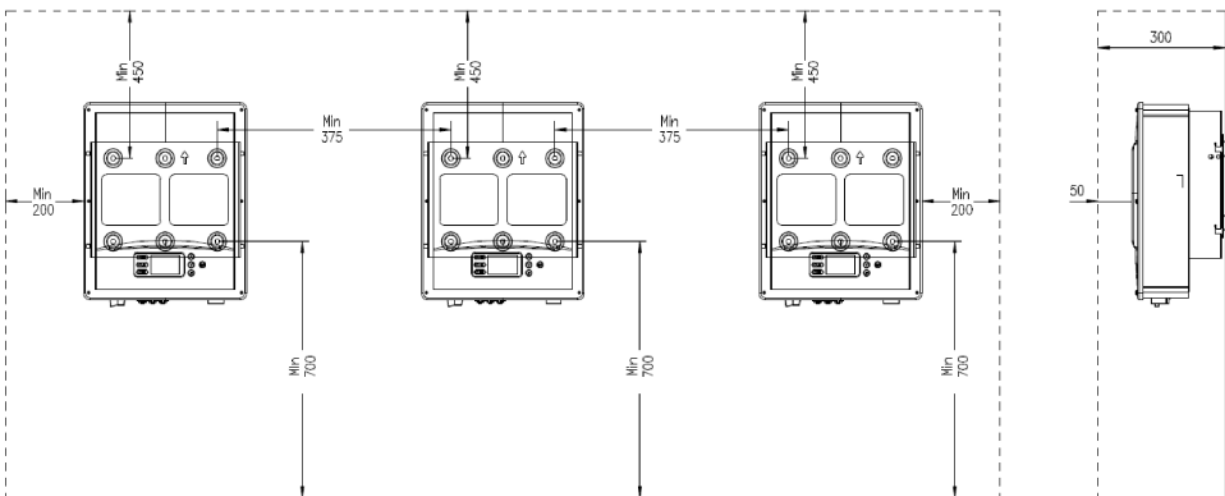

Clearances for multiple inverters

6. In order to avoid power reduction caused by overheating, do not mount the inverter in a location that allows long-term exposure to direct sunlight.

7. Ensure optimum operation and extend service life, avoid exposing the inverter to direct sunlight, rain and snow.

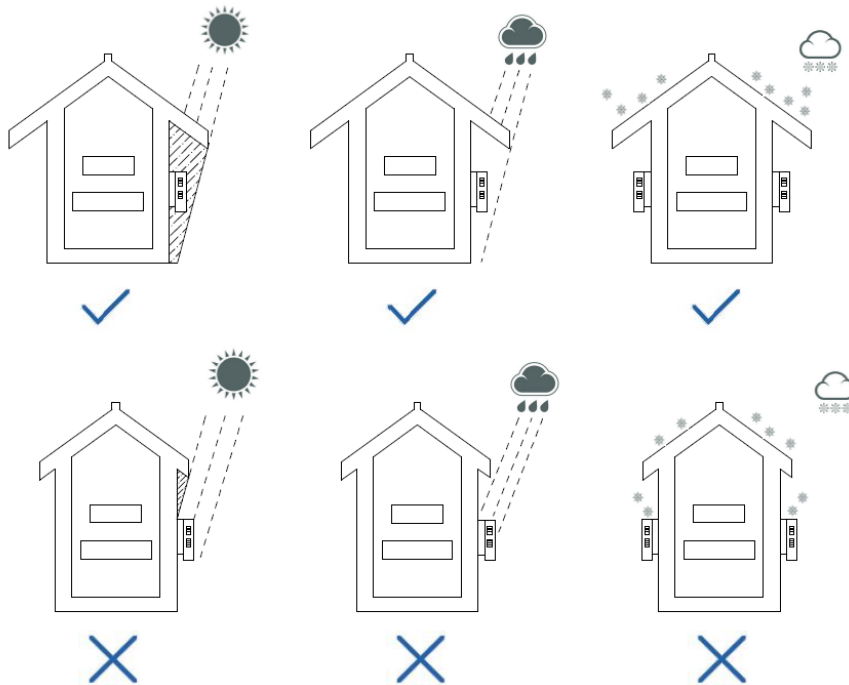

8. The mounting method, location and surface must be suitable for the inverter's weight and dimensions.
9. If mounted in a residential area, we recommend mounting the inverter on a solid surface. Plasterboard and similar materials are not recommended due to audible vibrations when in use.
10. Don't put any objects on the inverter. Do not cover the inverter.

4.2 Selecting the mounting location

WARNING

Danger to life due to fire or explosion

- Do not mount the inverter in areas containing highly flammable materials or gases.
- Do not mount the inverter in a potentially explosive atmosphere.

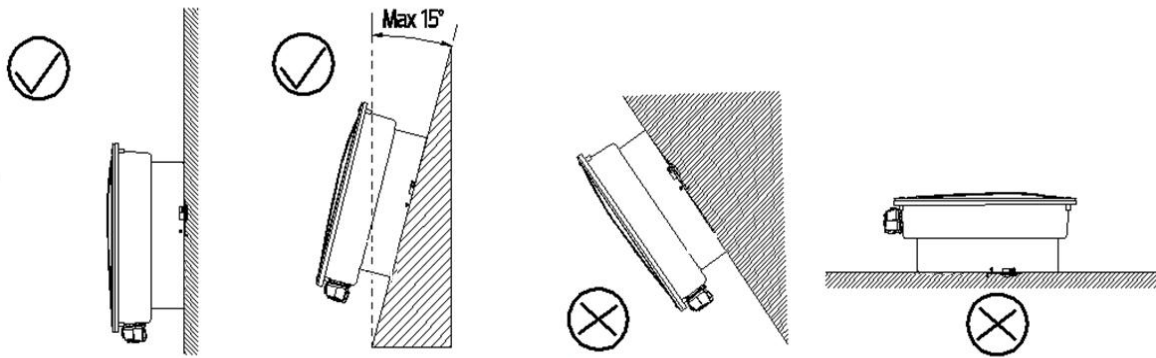

1. Mount the inverter vertically or tilted backward by max. 15°.
2. Never mount the inverter tilted forward or sideways.
3. Never mount the inverter horizontally.
4. Mount the inverter at eye level to make it easy to operate and read the display.
5. The electrical connection area must point downwards.

4.3 Mounting the inverter with the wall bracket

CAUTION

Risk of injury when lifting the inverter, or if it is dropped

The weight of Evershine is max. 24 kg. There is risk of injury if the inverter is lifted incorrectly or dropped while being transported or when attaching it to or removing it from the wall bracket.

- Transport and lift the inverter carefully.
- Two people are needed to mount the inverter.

CAUTION

Risk of injury due to damaged cables

There may be power cables or other supply lines (e.g. gas or water) routed in the wall.

- Ensure that no lines are laid in the wall which could be damaged when drilling holes.

Mounting procedure:

1. Use the wall bracket as a drilling template and mark the positions of the drill holes, then drill 4 holes ($\Phi 10$) to a depth about 70mm. During operation, keep the drill vertical to the wall, and hold the drill steady to avoid tilted holes.

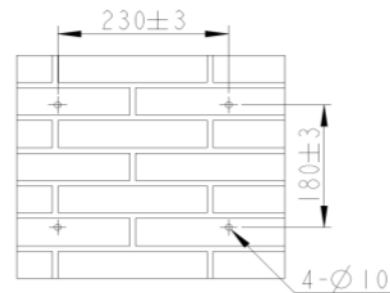

2. After cleaning the dust and other objects from the holes, place 4 wall anchors into the holes, then attach the wall bracket to the wall using the hexagon head screw delivered with the inverter.

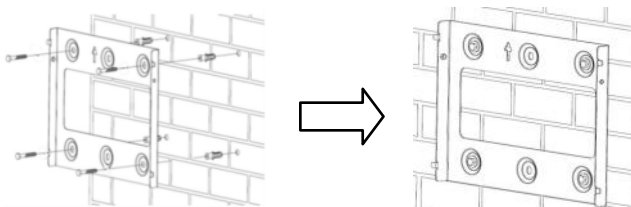

3. Hold the inverter using the handles at the corners, attach the inverter onto the wall bracket tilted slightly downwards.

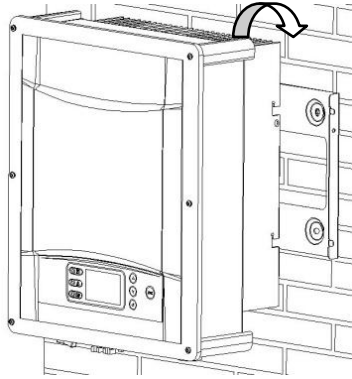

4. Check both sides of the outer fin of the inverter to ensure that it is securely in place.

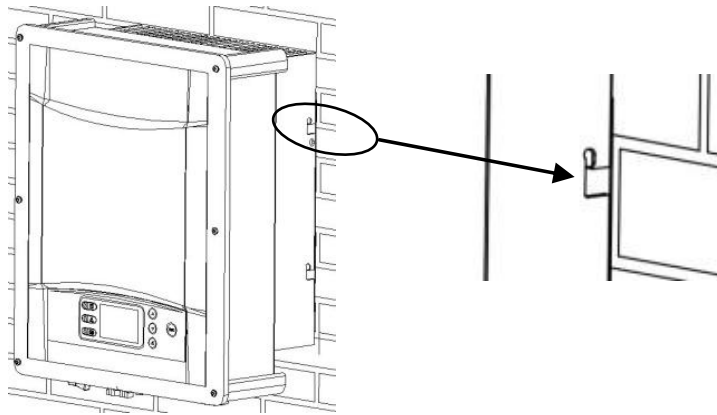

5. Attach the outer fins of heat sink to both sides of the wall bracket using M5 screws. (screw driver type: T25, torque: 2.5Nm).

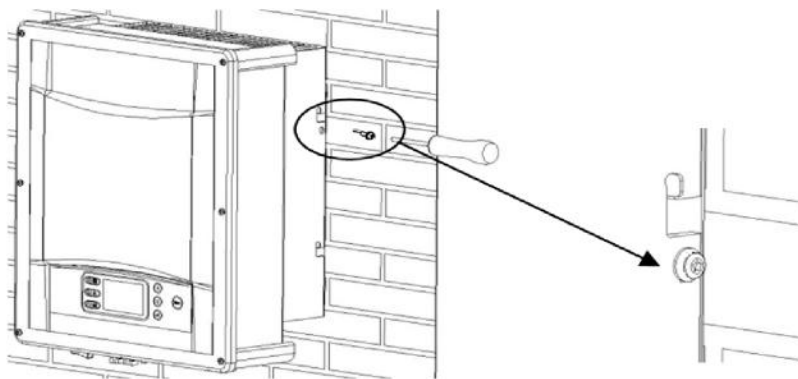

If a second protective conductor is required locally, ground the inverter and secure it so that it cannot be lifted off the wall bracket (see section 5.4.3 “Second protective grounding connection”).

5 Electrical connection

5.1 Safety

WARNING

Danger to life due to high voltages of the PV array

When exposed to sunlight, the PV array generates dangerous DC voltage which is present in the DC conductors and the live components of the inverter. Touching the DC conductors or the live components can lead to lethal electric shocks. If you disconnect the DC connectors from the inverter under load, an electric arc may occur leading to electric shock and burns.

- Do not touch non-insulated cable ends.
- Do not touch the DC conductors.
- Do not touch any live components of the inverter.
- Have the inverter mounted, installed and commissioned only by qualified persons with the appropriate skills.
- If an error occurs, have it rectified by qualified persons only.
- Prior to performing any work on the inverter, disconnect it from all voltage sources as described in chapter 8.

CAUTION

Risk of injury due to electric shock

- The external protective grounding conductor is connected to the inverter's protective grounding terminal through the AC connector. Make sure the connection is reliable.
- When connecting, connect the AC connector first to ensure the inverter grounding reliably and then connect the DC inputs.
- When disconnecting, disconnect the DC inputs first and then disconnect the AC connector
- Don't connect the DC inputs while the AC connector is disconnected under any circumstances.
- All electrical installations must be done in accordance with the National Wiring Rules Standards and Local Code.

5.2 System layout of units without integrated DC-switch

Local standards or codes may require that PV systems are fitted with an external DC-switch on the DC side. The DC-switch must be able to safely disconnect the open-circuit voltage of the PV array plus a safety reserve of 20%.

Install a DC-switch to each PV array to isolate the DC side of the inverter. We recommend the following electrical connection:

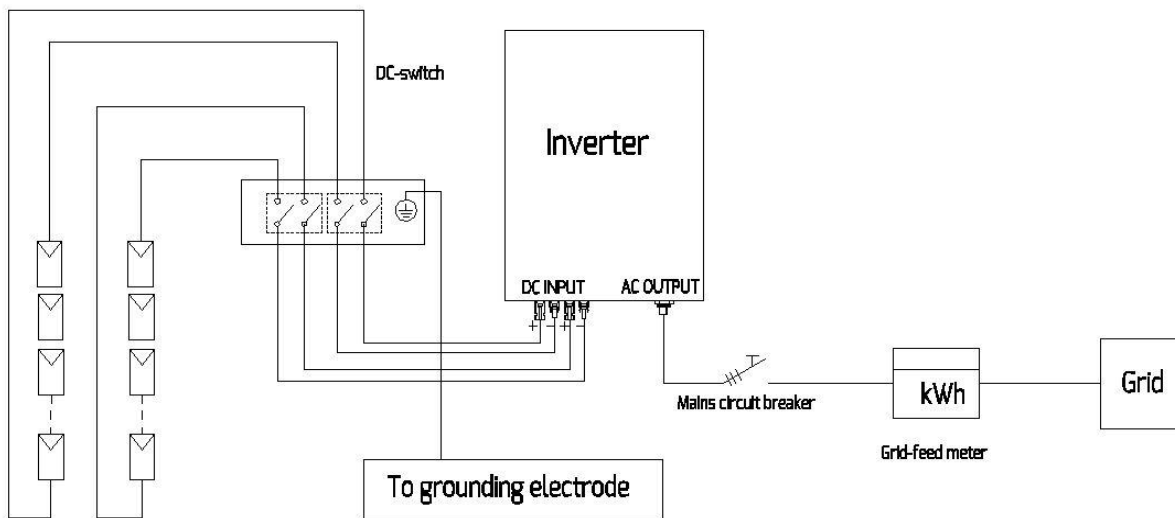

5.3 Overview of the connection area

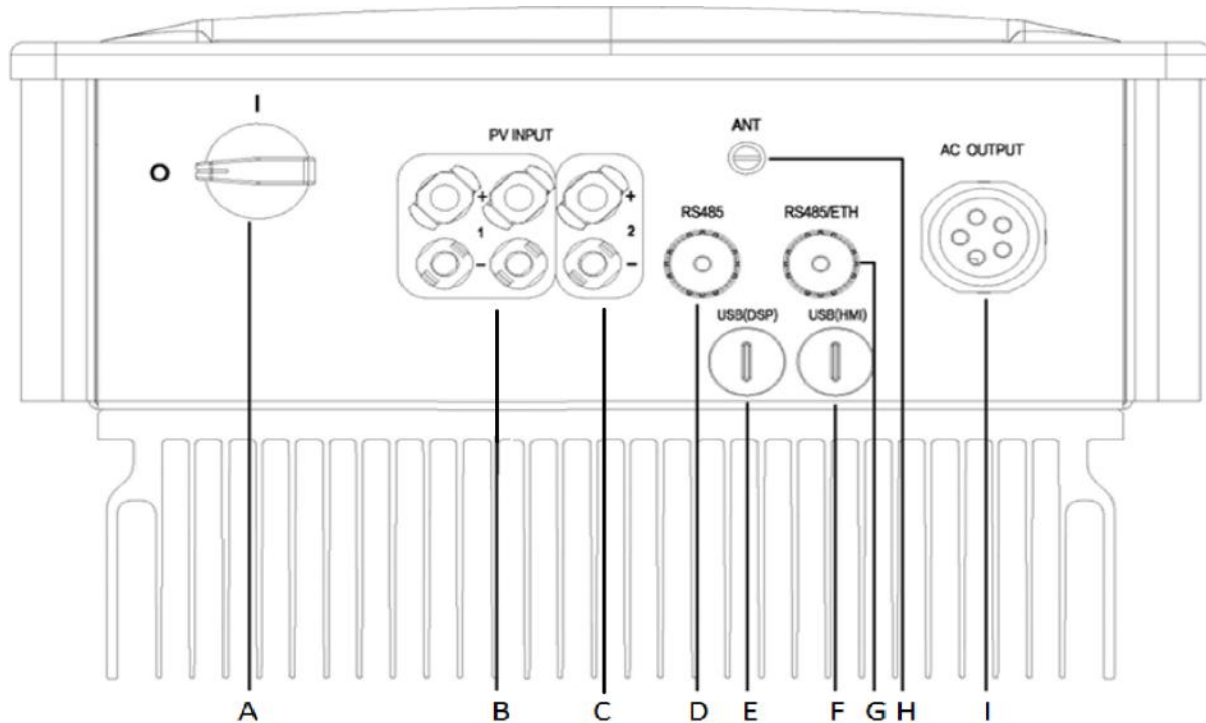

Object	Description
A	DC-switch (optional): switch on or off for PV-load
B	DC input area 1: plug-in connectors to connect the strings (only one pairs for Evershine TLC4000-6000)
C	DC input area 2: plug-in connectors to connect the strings
D	If you choose the inverter integrated with RS485 module, C is communication interfaces for connecting the monitoring device. If you chose the inverter integrated with Ethernet module, C is not used.
E	USB (DSP) interface: update the firmware
F	USB (HMI) interface: update the software
G	RS485/ETH(optional) interface: connect the monitoring device
H	ANT (optional): antenna, transmit and receive wifi signal.
I	AC output: plug-in connector to connect the grid

5.4 AC Connection

⚠ DANGER

Danger to life due to high voltages in the inverter

- Before performing the electrical connection, ensure that the AC circuit-breaker is switched off and cannot be reactivated.

5.4.1 Conditions for the AC connection

Cable Requirements

The grid connection is made using 5 conductors (L1, L2, L3, N, and PE). We recommend the following requirements for stranded copper conductor.

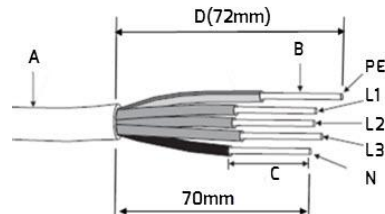

Object	Description	Value
A	External diameter	12...21 mm
B	Conductor cross-section	2.5...6 mm ²
C	Stripping length of the insulated conductors	Approx. 9 mm
D	Stripping length of the AC cable's outer sheath	Approx.72 mm
The PE insulated conductor must be 2 mm longer than the L and N conductors		

Larger cross-sections should be used for longer leads.

Cable Design

The conductor cross-section should be dimensioned to avoid power loss in cables exceeding 1% of rated output power.

The maximum cable lengths relative to the conductor cross-section as follows:

	Maximum cable length				
	TLC4000	TLC5000	TLC6000	TLC8000	TLC10000
4 mm ²	65 m	53 m	43 m	34 m	27 m
6 mm ²	98 m	80 m	65 m	51 m	41 m

The required conductor cross-section depends on the inverter rating, ambient temperature, routing method, cable type, cable losses, valid installation requirements of installation side.

5.4.2 Grid connection

Overview of the AC connection plug

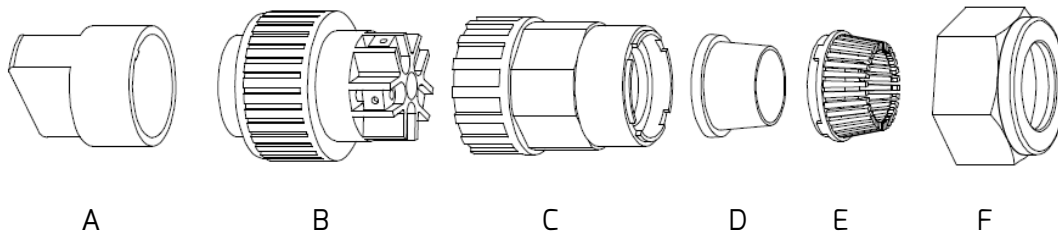

	Object	Description	
Accessory	A	Plastic fixture (only for griding easily, remove it after tightening the AC connection plug)	
AC Connection Plug	B	Socket element	
	C	Adapter	
	D*	Seal ring	Thicker seal ring is suitable for cable diameter 12-18mm
			Thinner seal ring is suitable for cable diameter 16-21mm
	E	Fastening case	
F	Swivel nut		

* There are two seal rings in the AC connection plug kit, please choose the suitable one according to different cable external diameter.

Procedure:

1. Switch off the AC circuit breaker and secure it against reconnection.
2. Guide the swivel nut, the fastening case with sealing ring and the adapter over the AC cable.

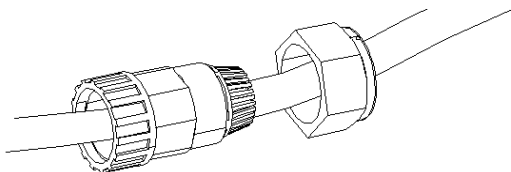

3. Strip the cable's outer sheath (72mm) and the conductors' insulation (9mm).

4. Insert the bared conductors into the suitable cord end terminals and crimp them by using a crimper.

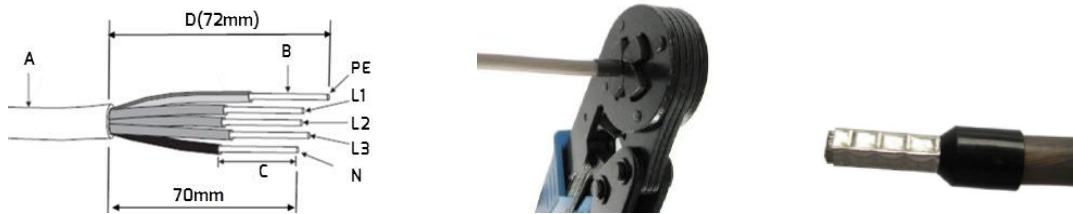

5. Insert the crimped conductors L1, L2, L3, N and PE into the corresponding terminals and tighten the screw with torque 2.0Nm using an Allen key (AF 2.5).

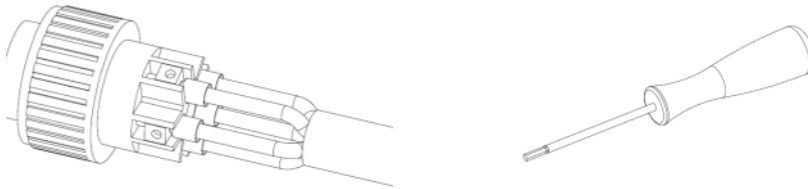

⚠ CAUTION

Damage to the inverter due to wrong wiring

- Please ensure that the type of the conductors matches the signs of the terminals on the socket element.

6. Assemble the socket element, adapter and swivel nut together. Match the plastic fixture with the socket element and grip them, then screw the adapter and swivel nut as shown below with a torque of 4Nm.

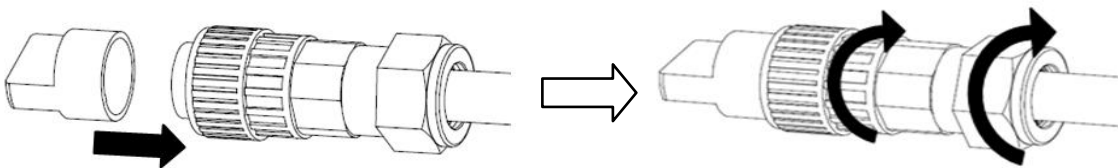

7. Insert the AC connect plug into the receptacle on the inverter, then screw the socket element clockwise until it snaps into place.

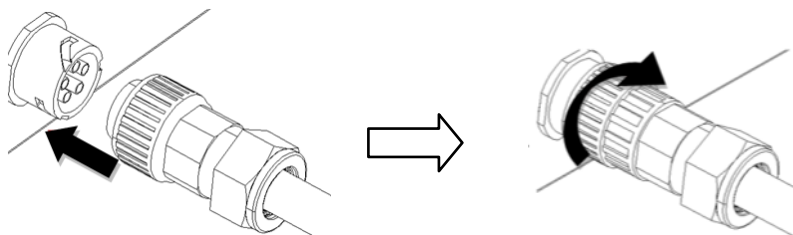

5.4.3 Second protective grounding connection

If required, the grounding terminal can be used to connect a second protective conductor or as equipotential bonding.

Procedure

1. Take out the terminal lug (OT6-5), insert the stripped grounding conductor into the terminal lug and crimp the contact.
2. Align the terminal lug with protective conductor and the ground washer on the screw. The teeth of the ground washer must be facing the heat sink.
3. Insert the screw through the hole located at the outer fin of the heat sink and tighten it into the wall bracket firmly (screw driver type: T25, torque: 2.5Nm).

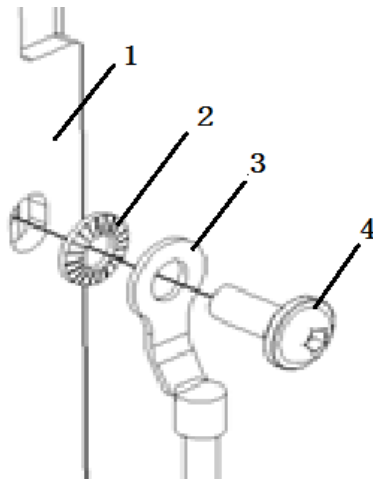

Grounding parts information:

No.	Description
1	Heatsink
2	Ground washer
3	Terminal lug (OT6-5) with protective conductor
4	M5×12 pan head screw

5.4.4 Residual current protection

The inverter is equipped with an all-pole sensitive residual current monitoring unit (RCMU) with an integrated differential current sensor which fulfills the requirement of DIN VDE 0100-712 (IEC60364-7-712:2002).

Therefore, an external residual current device (RCD) is not required. If an external RCD needs to be installed because of local regulations, a RCD type A or type B can be installed as an additional safety measure.

The all-pole sensitive residual current monitoring unit (RCMU) detects alternating and direct differential currents. The integrated differential current sensor detects the current difference between the neutral conductor and the line conductors. If the current difference increases suddenly, the inverter disconnects from the grid. The function of the all-pole sensitive residual current monitoring unit (RCMU) has been tested according to IEC 62109-2.



For installing an external residual current device (RCD)

Where an external residual current device (RCD) is required in a TT or TN-S system, install a residual current device which trips at a residual current of 100mA or higher.

For each connected inverter, a rated residual current of 100mA has to be provided. The rated residual current of the RCD must be equal to at least the sum of the rated residual currents of the connected inverters. That means that, if, for example, 2 transformerless inverters are connected, the rated residual current of the RCD must be at least 200mA.

5.4.5 Overvoltage category

The inverter can be deployed in grids of installation category III or lower, as defined under IEC 60664-1. This means that it can be permanently connected at the grid-connection point in a building. In installations involving long outdoor cable routing, additional overvoltage-reducing measures must be taken so that the overvoltage category is reduced from IV to III.

5.4.6 AC circuit breaker

DANGER

Danger to life due to fire

You must safeguard each inverter with an individual AC circuit breaker in order that the inverter can be disconnected safely.

No consumer load should be applied between AC circuit breaker and the inverter. The selection of the AC circuit breaker rating depends on the wiring design (wire cross-section area), cable type, wiring method, ambient temperature, inverter current rating, etc. Derating of the AC circuit breaker rating may be necessary due to self-heating or if exposed to heat.

The maximum output current of the inverters and recommended AC circuit breaker can be found in the following table.

Type	Max. output current	Recommended AC circuit breaker rating
TLC4000	6.0 A	16A
TLC5000	7.5 A	
TLC6000	9.1 A	
TLC8000	12.1 A	20A
TLC10000	15.2 A	

5.5 DC connection

DANGER

Danger to life due to high voltages in the inverter

- Before connecting the PV generator, ensure that the DC-switch is switched off and that it cannot be reactivated.
- Do not disconnect the DC connectors under load.

5.5.1 Requirements for the DC connection



Information for use Y adaptors

Y adaptors must not be visible or freely accessible in the immediate vicinity of the inverter.

- The DC circuit must not be interrupted by Y adaptors
- In order to interrupt the DC electric circuit, disconnect the inverter from all voltage sources.

- Requirements for the PV modules per MPP input;
 - The same type
 - The same number of series-connected PV modules
 - Identical alignment
 - Identical tilt
- The thresholds for the input voltage and the input current of the inverter must be adhered to (see Section 10.1 "Technical DC input data").
- On the coldest day based on statistical records, the open-circuit voltage of the PV array must never exceed the maximum input voltage of the inverter.
- The connection cables of the PV modules must be provided with the connectors
- The positive connection cables of the PV modules must be fitted with the positive DC connectors. The negative connection cables of the PV modules must be provided with the negative DC connectors.

5.5.2 Assembling the DC connectors

DANGER

Danger to life due to high voltages on DC conductors

When exposed to sunlight, the PV array generates dangerous DC voltage which is present in the DC conductors. Touching the DC conductors can lead to lethal electric shocks.

- Cover the PV modules.

Assemble the DC connectors as described below. Be sure to observe the correct polarity. The DC connectors are marked with the symbols "+" and "-".

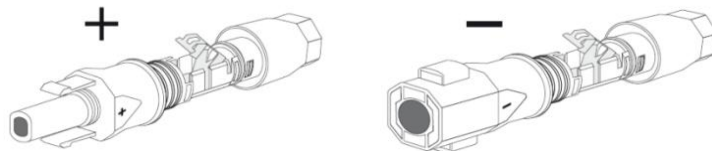

Cable requirements:

The cable must be of type PV1-F, UL-ZKLA or USE2 and comply with the following properties:

- ✧ External diameter: 5-8mm
- ✧ Conductor cross-section: 2.5-6mm²
- ✧ Qty single wires: minimum 7
- ✧ Nominal voltage: minimum 1000V

Proceed as follows to assemble each DC connector.

1. Strip 12 mm of the cable insulation.

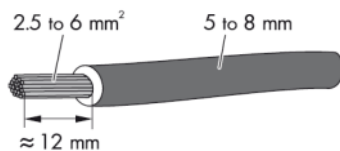

2. Route the stripped cable all the way into the DC connector. Ensure that the stripped cable and the DC connector have the same polarity.

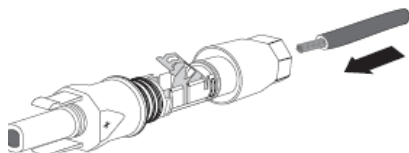

3. Press the clamping bracket down until it audibly snaps into place.

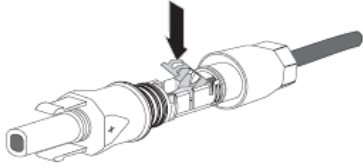

4. Ensure that the cable is correctly positioned:

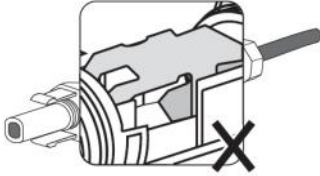
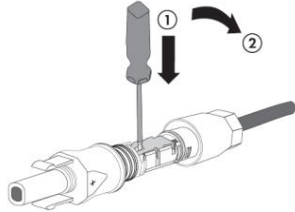
Result	Measure
<p>If the stranded wires are visible in the chamber of the clamping bracket, the cable is correctly positioned.</p> 	<p>•Proceed to step 5.</p>
<p>If the stranded wires are not visible in the chamber, the cable is not correctly positioned.</p> 	<p>•Release the clamping bracket. To do so, insert a flat-blade screwdriver (blade width: 3.5 mm) into the clamping bracket and lever it open.</p>  <p>•Remove the cable and go back to step 2.</p>

5. Push the swivel nut up to the thread and tighten (torque: 2 Nm).

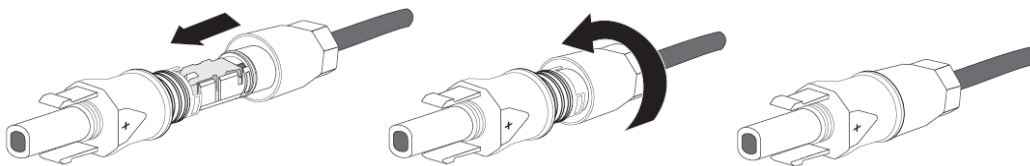

5.5.3 Disassembling the DC connectors

DANGER

Danger to life due to high voltages on DC conductors

When exposed to sunlight, the PV array generates dangerous DC voltage which is present in the DC conductors. Touching the DC conductors can lead to lethal electric shocks.

- Cover the PV modules.
- Do not touch the DC conductors.

1. Set the DC-Switch of the inverter to position "0".
2. Unscrew the swivel nut.



3. To release the DC connector, insert a flat-blade screwdriver (blade width: 3.5 mm) into the side catch mechanism and lever open.

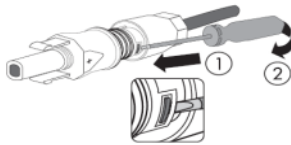

4. Carefully pull the DC connector apart.

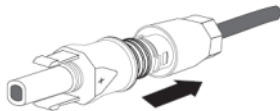

5. Release the clamping bracket. To do so, insert a flat-blade screwdriver (blade width: 3.5 mm) into the clamping bracket and lever it open.

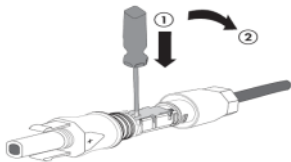

6. Remove the cable.

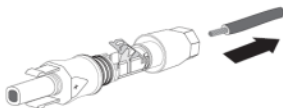

5.5.4 Connecting the PV Array

NOTICE

Damage to the inverter due to overvoltage

If the voltage of the strings exceeds the maximum DC input voltage of the inverter, it can be destroyed due to overvoltage. All warranty claims become void.

- Do not connect strings with an open-circuit voltage greater than the maximum DC input voltage of the inverter.
- Check the design of the PV system

1. Ensure that the individual AC circuit breaker is switched off and secure it against reconnection.
2. Ensure that the DC-switch is switched off and secure it against reconnection.
3. Ensure that there is no ground fault in the PV strings.
4. Check whether the DC connector has the correct polarity.

If the DC connector fits with a DC cable having the wrong polarity, the DC connector must be reassembled again. The DC cable must always have the same polarity as the DC connector.

5. Ensure that the open-circuit voltage of the PV strings does not exceed the maximum DC input voltage of the inverter.
6. Connect the assembled DC connectors to the inverter until they audibly snap into place.

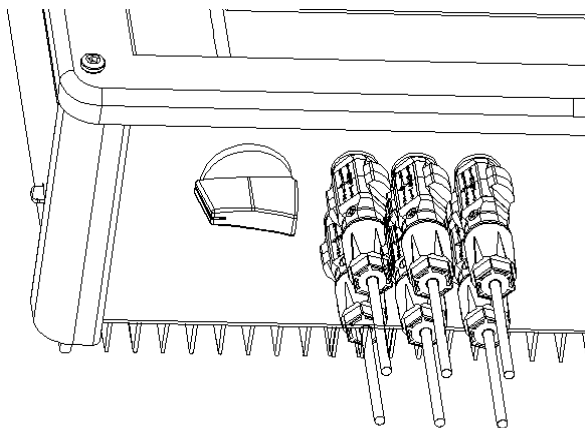

NOTICE

Damage to the inverter due to moisture and dust penetration

Seal the unused DC inputs with sealing plugs so that moisture and dust cannot penetrate the Inverter.

- Make sure all DC connectors are securely sealed.

7. Insert the sealing plugs provided into the DC plug connectors which are not used.

- For unused DC connectors, push down the clamping bracket and push the swivel nut up to the thread.

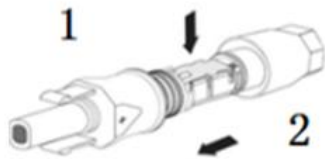

- Insert the sealing plug into the DC connector.

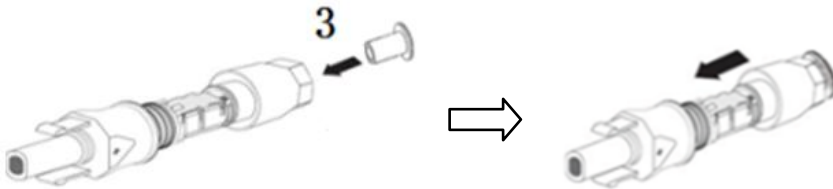

- Tighten the DC connector (torque: 2 Nm).

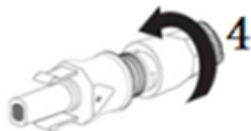

- Insert the DC connectors with sealing plugs into the corresponding DC inputs on the inverter.

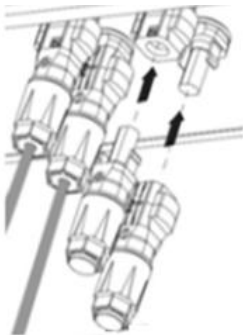

6 Communication

6.1 System monitoring via RS485

The inverter integrated with RJ45 interface for communication connection. Monitoring them can be achieved by connecting multiple inverters in series on a RS485 bus, and eventually to ZeverManager. The overall length of the network cable should not exceed 1000m. The monitoring system layout for inverters is as follows:

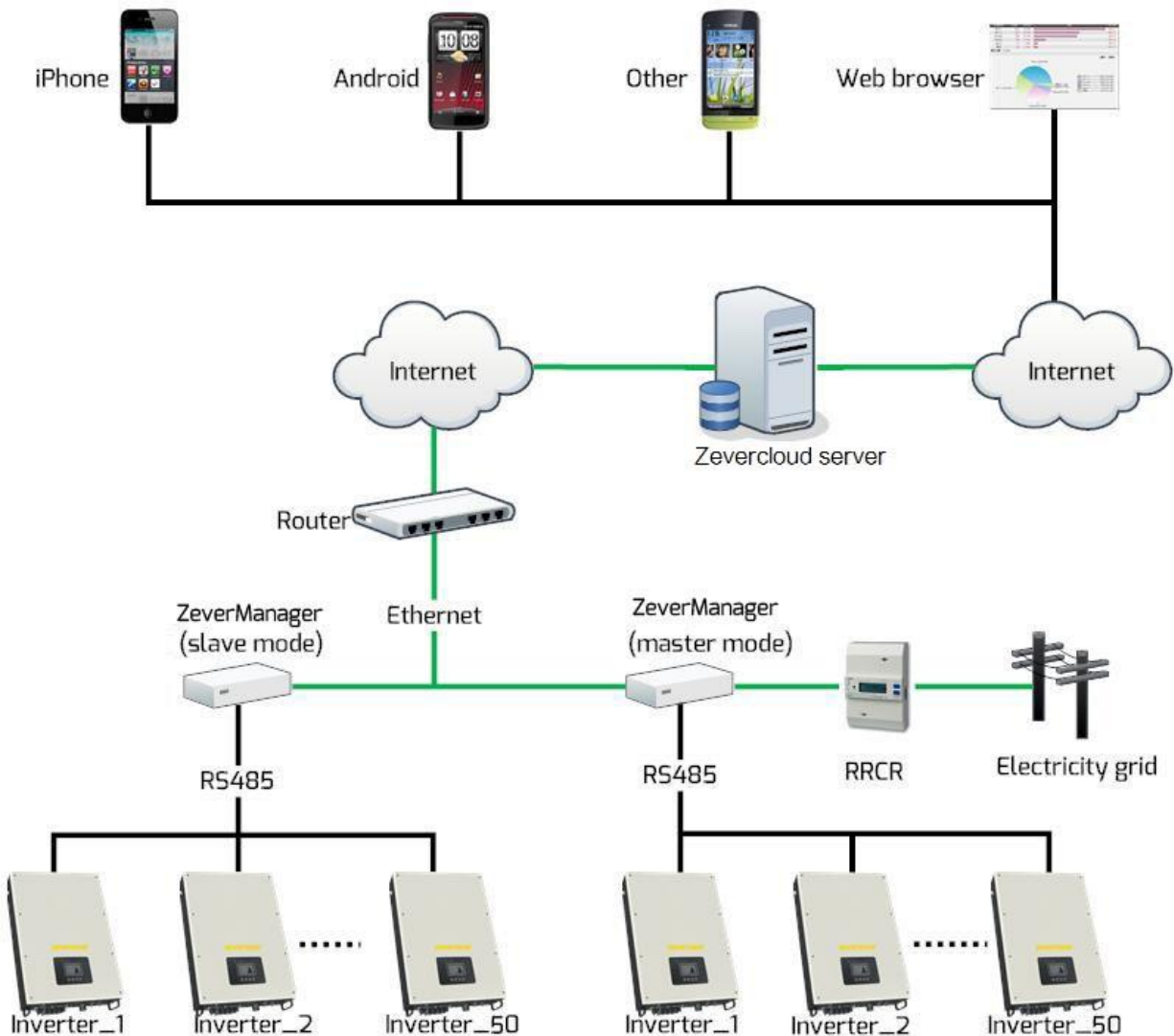

ZeverManager connects to the inverter via the RJ45 interface, and it connects to the router via Ethernet. Then you will be able to connect the inverter to the remote monitoring platform “ZeverCloud”. You can monitor the operating status or power

generation data via a smart phone or PC. The website address of the “ZeverCloud” is www.zevercloud.com

Pinout detail of the RJ45 interface on the inverter as follows:

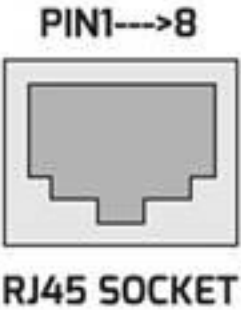
Pin1----- TX_RS485A	
Pin2-----TX_RS485B	
Pin3-----RX_RS485A	
Pin4-----GND	
Pin5-----GND	
Pin6-----RX_RS485B	
Pin7-----+7V	
Pin8-----+7V	

For detailed information, please refer to ZeverManager user manual.

CAUTION

CAT-5 with shield or higher level cable is required as the RS485 communication cable between inverter and ZeverManager. Pinout detail on both ends of the cable should comply with TIA/EIA568A or 568B standard.

The cable shall be UV resistant if used outdoor.

NOTICE

Damage to the inverter due to moisture and dust penetration

If the RJ45 plugs are not installed or not installed correctly, the inverter will be destroyed due to moisture and dust entering and corroding the RJ45 port. All warranty claims become void.

Make sure the RJ45 plug has been installed correctly and tightened firmly.

Connecting the RJ45 plug:

1. Unscrew the cap nut from the RJ45 keystone socket.

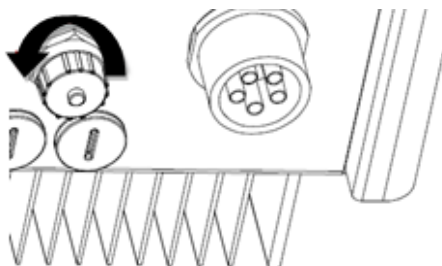

2. Take out the RJ45 plug which accompanies the inverter, and disassemble it.

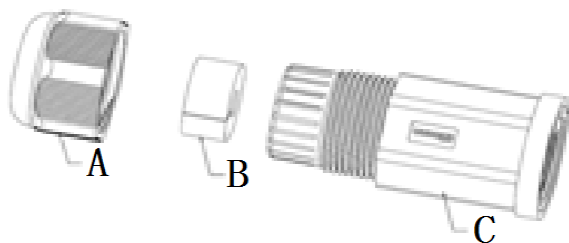

Object	Description
A	Swivel nut
B	Seal
C	Threaded sleeve(with gasket)

3. Guide the network cable through the components of RJ45 plug as follows.

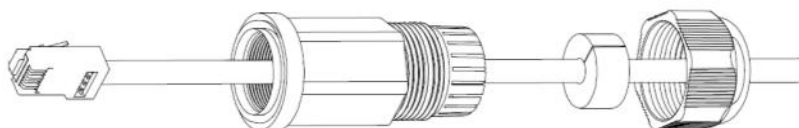

4. Insert the network cable to the RJ45 keystone socket then screw the threaded sleeve to the RJ45 socket tight by hand.

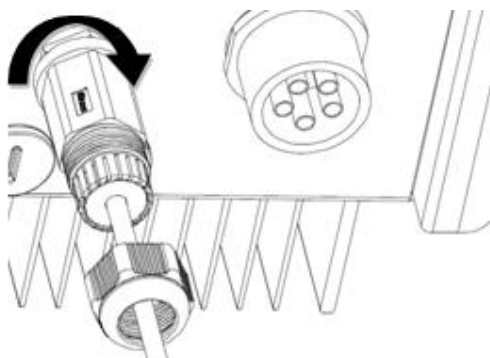

5. Push the seal into the threaded sleeves, screw the swivel nut to the threaded sleeve tight by hand.

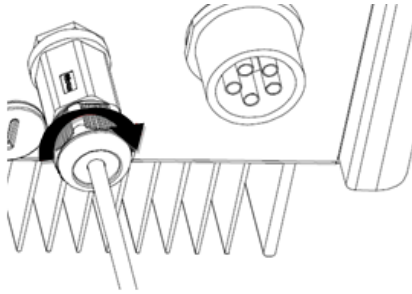

Disassemble the RJ45 plug:

1. Unscrew the swivel nut.

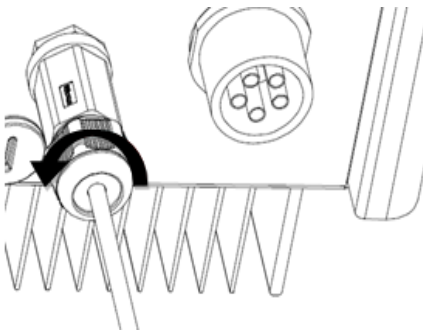

2. Unscrew the threaded sleeve.

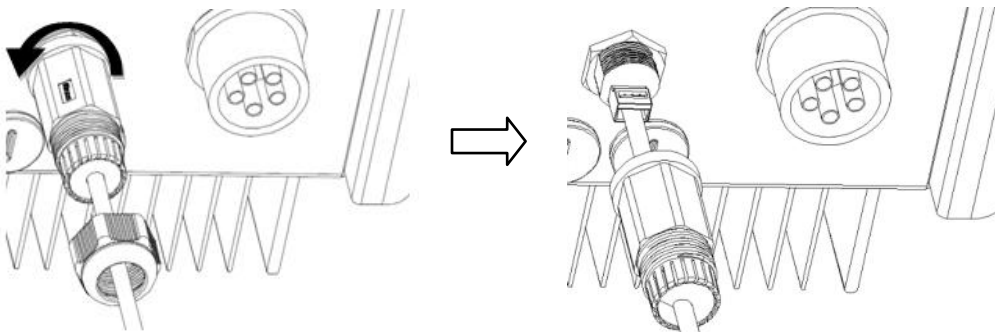

3. Remove the network cable and then screw the cap nut to the RJ45 keystone socket by hand.

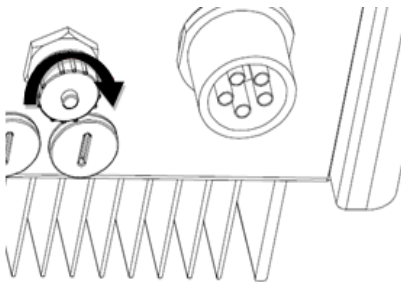

6.2 System monitoring via Ethernet

User can monitor the inverter through the integrated Ethernet module (optional). The connection diagram between the inverter and internet with network cable is shown as follows.

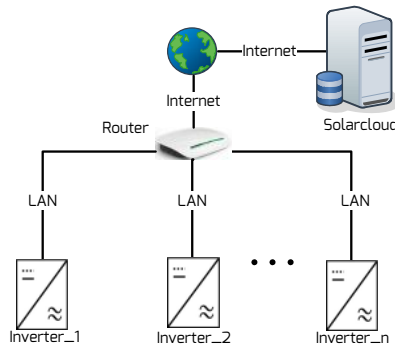

Possible reason of communication failure due to closed port

Port #6655~#6660 is used to transfer data to Zevercloud. These ports must be opened, or else the Ethernet module cannot communicate with the Zevercloud and upload data.

For network cable connection between the router and the Ethernet port on the Ethernet module, please refer to the relative instruction at section 6.1.



Possible reason of communication failure due to DHCP

The router needs to support DHCP services if the Ethernet module uses the DHCP function.

The inverter obtains an IP address from the router via DHCP automatically and shows it on the display. It takes time to connect to the network depending on the network communication conditions.

6.3 System monitoring via WiFi

User can monitor the inverter through the integrated Ethernet module with WiFi module (optional). The connection diagram between the inverter and internet with a WiFi connection is shown as follows.

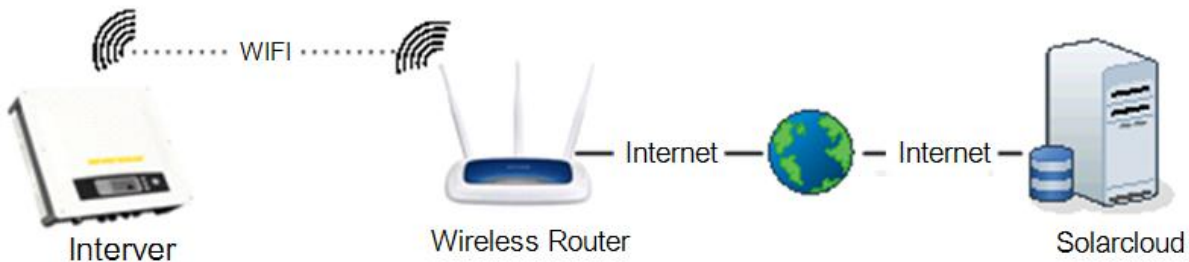

Installation steps of the antenna:

1. Take the antenna included in the scope of delivery.
2. Remove the sealing plug on the WiFi connection port.
3. Tighten the antenna to the WiFi connection port by hand. Make sure the antenna is securely connected.

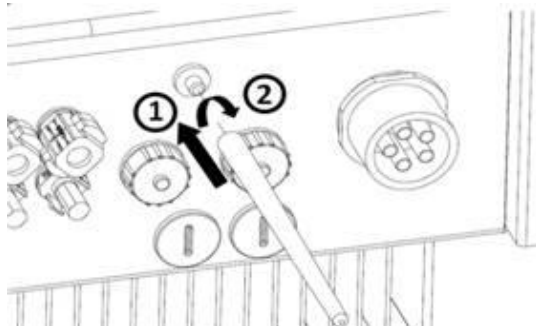

6.4 Communication with a third party monitoring device

This inverter supports communication with the third party monitoring device such as Metecontrol, Solar-Log etc. For detailed wiring method, please refer to operating manual of corresponding third party monitoring device.

6.5 Updating the firmware via USB

If need to update the firmware, use a flat-blade screwdriver (blade width: 9 mm) to unscrew the M20 screw plugs located at the bottom of the housing.

7 Commissioning

NOTICE

Risk of injury due to the faulty installation

We strongly recommend carrying out preliminary checks before commissioning to avoid possible damage to the device caused by faulty installation.

7.1 Electrical check

Carry out the main electrical checks as follows:

- ① Check the PE connection with a multimeter: check that the inverter's exposed metal surface has a grounding connection.

WARNING

Danger to life due to the presence of DC-Voltage

- Only touch the insulation of the PV array cables,
- Do not touch parts of the sub-structure and frame of the PV array which isn't grounded,
- Wear personal protective equipment such as insulating gloves,

- ② Check the DC voltage values: make sure that the DC voltage of the strings does not exceed the permitted limits.
- ③ Check the polarity of the DC voltage: make sure the DC voltage has the correct polarity.
- ④ Check the PV generator's insulation to ground with a multimeter: make sure that insulation resistance to ground is greater than 1MΩ.

WARNING

Danger to life due to the presence of AC-Voltage

- Only touch the insulation of the AC cables.
- Wear personal protective equipment such as insulating gloves.

⑤ Check the grid voltage: check that the grid voltage at the point of connection of the inverter is within the permitted range.

7.2 Mechanical check

Carry out the main mechanical checks to ensure the inverter is waterproof as follows:

- ① Use sealing plugs for tight sealing of unused DC input connectors.
- ② Make sure the cap nut on the unneeded RJ45 keystone socket has been correctly tightened.
- ③ Make sure the AC connector has been installed correctly.

7.3 Start-up

After finishing the electrical and mechanical checks, switch on the AC circuit breaker and DC-switch in turn. Ensure the correct safety setting has been selected for the region. The inverter starts up automatically.

Usually, there are three states during operation.

Waiting: Only when the initial voltage of the strings is greater than the start-up DC voltage, the inverter will start. Once the input voltage is out of the range from 180V to 950V, the inverter will be in waiting state and cannot feed power into the grid.

Checking: When the initial voltage of the strings exceeds the start-up DC input voltage, the inverter will check feeding conditions at once. If there is anything wrong during checking, the inverter will switch to the “Fault” mode.

Normal: After checking, the inverter will switch to “Normal” state and feed power into the grid.

During periods of low irradiation, the inverter may continuously startup and shut down. This is due to insufficient power generated by the PV generator. If this fault occurs often, contact the service.



Quick troubleshooting

If the inverter is in “Fault” mode, refer to chapter 11 “Troubleshooting”.

8 Disconnecting the inverter from voltage sources

Before performing any work on the inverter, disconnect it from all voltage sources as described in this section. Always adhere strictly to the given sequence.

1. Disconnect AC circuit breaker and secure against reconnection.
2. Disconnect the DC-switch and secure against reconnection.
3. Use a current probe to ensure that no current is present in the DC cables.
4. Release and disconnect all DC connectors. To do so, insert a flat-blade screwdriver or an angled screwdriver (blade width: 3.5 mm) into one of the side and pull the DC connectors straight out. Do not pull on the cable.

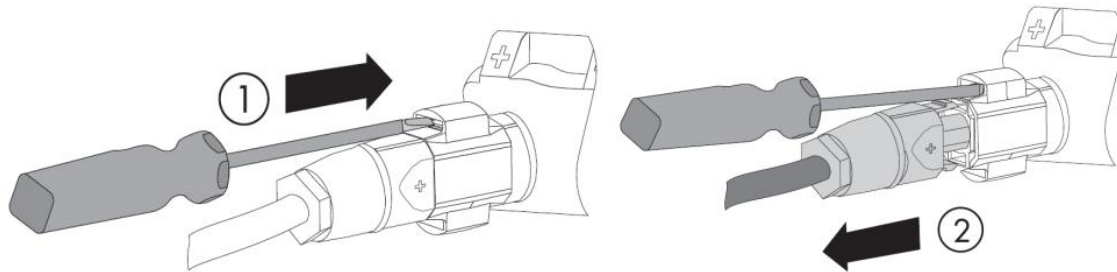

5. Release and disconnect the AC connector. Rotate the socket element counter-clockwise to open.

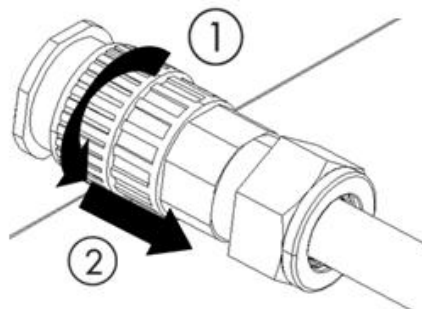

6. Wait until all LEDs and the display have gone out.

⚠ DANGER

The capacitors in the inverter take 5 minutes to discharge.

- Wait 5 minutes before performing any work on the inverter.

9 Operating

9.1 Overview of the control panel

The inverter is equipped with a control panel which includes a LCD, three LED indicators and four control buttons. You can view the data and set the parameters of the inverter using the control buttons.

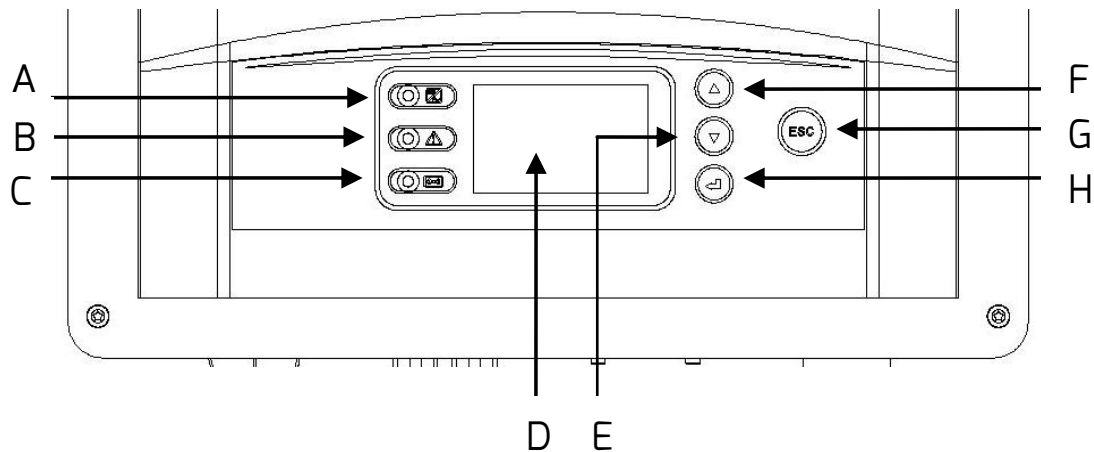

Object	Description
A	Normal (Green LED)
B	Fault (Red LED)
C	Communication (Bicolor LED)
D	LCD
E	▼ (Down button)
F	▲ (Up button)
G	ESC (Exit button)
H	↵ (Enter button)

9.2 LED indicators

The inverter is equipped with three LED indicators including “green”, “red” and “bicolor” which provide information about the various operating status as follows.

Green LED:

The green LED is lit when the inverter is operating normally.

Red LED:

The red LED is lit when the inverter has stopped feeding power into the grid due to a fault. The corresponding error code will be shown on the display at the same time.

Bicolor LED:

The bicolor LED can blink green or red. It blinks during communication with other devices such as ZeverManager, Solarlog, etc. The LED blinks green when ZeverManager is sending information to the inverter, and blinks red when the inverter is sending information to the ZeverManager. The LED will be lit with green during firmware updating.

9.3 Display messages

Along with the various operating states, various messages may be shown on the display as follows.

State	Error code	Description	Causes
Initialization		Waiting	Initial PV voltage is between Min.DC input voltage and start-up DC input voltage of the inverter.
		Checking	The inverter is checking feeding conditions after initial PV voltage exceeds start-up DC input voltage of the inverter.
		Reconnect	The inverter is checking feeding conditions after the last fault has been solved.
Normal		Normal	The inverter is operating normally.
Fault	1	SPI Fault	Communication between the master and slave CPU has failed.
	2	EEPROM R/W Fault	Reading or writing of EEPROM fails
	3	Rly-Check Fault	Output relay has failed.
	4	DC INJ. High	DC injection of the output current exceeds the permitted upper limit.
	8	AC HCT Fault	Output current sensor is abnormal.
	9	GFCI Fault	GFCI detection circuit is abnormal.
	10	Device Fault	Unknown Error
	11	M-S version unmatched	Different firmware version between the master and slave CPU.
	33	Fac Fault	The grid frequency lies outside the permitted range.
	34	Vac Fault	The grid voltage lies outside the permitted range.
35	Utility Loss	The utility can not be detected, which may be caused by no utility, grid disconnected, AC cable damage, fuse broken or island.	

Fault	36	Ground Fault	The residual current exceeds the permitted upper limit.
	37	PV Overvoltage	The voltage of the strings exceeds the permitted upper limit.
	38	ISO Fault	The PV generator's insulation resistance to ground is below the permitted value, or the electrical insulation inside the inverter has failed.
	40	Over Temp.	The internal temperature exceeds the permitted value.
	41	Vac differs for M-S	A different value of grid voltage has been detected by the master and slave MCU.
	42	Fac differs for M-S	A different value of grid frequency has been detected by the master and slave MCU.
	43	Ground I differs for M-S	A different value of residual current has been detected by the master and slave MCU.
	44	DC Inj. differs for M-S	A different value of DC injection has been detected by the master and slave MCU.
	46	High DC Bus	The voltage of DC Bus exceeds the permitted upper limit.

The last 10 dated failure reports on the NS protection can be read from LCD. An interruption in the supply voltage of $\leq 3s$ does not result in any loss of failure reports (according to VDE-AR-N 4105).

ISO fault(error code 38) and Ground(error code 36) fault will trigger buzzer alarm. And it only happens when the safety of AU AS 4777.2 occupies.

9.4.2 Initial page

When the inverter starts up, LCD will first display an initial page that shows the current safety standard. The page will display for about 5 seconds and then jump to the home page automatically.

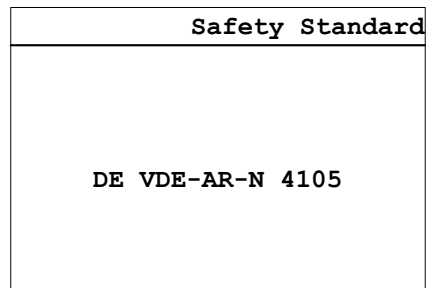

9.4.3 Unlock page

When the backlight of the LCD has turned off, press any key to activate. You need to touch the “▼” arrow and “Esc” buttons in sequence to unlock and enter the home page for operation.

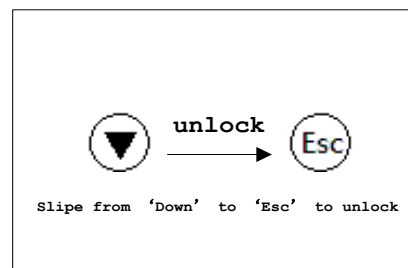

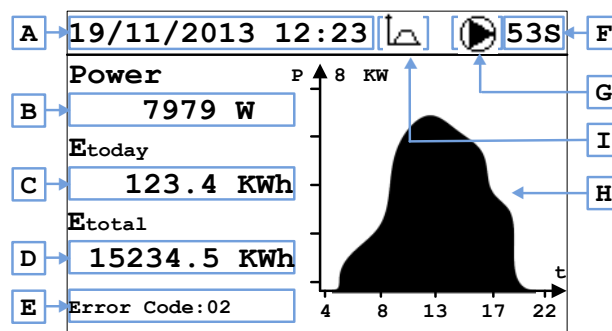

9.4.4 Home page

The home page shows important running data of inverter such as the real-time output power, daily energy, error code, and power graph.



The LCD will switch to standby mode and jump to the home page automatically, and the backlight will turn off when there is no button operation in 30 seconds.

Object	Description
A	Date&Time
B	Output power
C	Daily energy
D	Total energy
E	Error code*, see chapter 9.3
F	Checking time
G	Operating status:  waiting,  operating,  fault
H	Field area of output power from 4:00 to 22:00
I	Load limit Enable Indication

*The operating temperature of the inverter can't be lower than -25°C .The inverter goes into fault mode and stops power generation when the temperature is lower than -25°C. The LCD will show the error message "Temp. under -25°C".

9.4.5 Operation information

There are two pages showing the current operating data about the AC&DC sides of the inverter respectively. Switch between these 2 pages by pressing the "▲" or "▼" button.

Running Info			
A →	VacL1 236.1 V	IacL1 8.3 A	D ←
	VacL2 235.5 V	IacL2 8.5 A	
	VacL3 237.8 V	IacL2 8.1 A	
B →	PF 1.00	Phase Leading	E ←
C →	Fac 50.01 Hz	Runtime 12 h	F ←

Running Info			
G →	Vpv1 580.8 V	Ipv1 5.1 A	I ←
	Vpv2 579.2 V	Ipv2 5.3 A	
H →	Ppv1 2896 W	Ppv2 2798 W	J ←

Object	Description
A	Grid voltage
B	Power factor
C	Grid frequency
D	Output current
E	Phase leading or lagging
F	Running hours of the current day
G	DC input voltage
H	DC input power of MPPT 1
I	DC input current
J	DC input power of MPPT 2

9.4.6 Main menu

Press the "↵" button to enter the main menu from the home page.

Press the "▼" or "▲" button to select the menu item.

Press the "↵" button to confirm.

Press the "ESC" button to return to the home page.

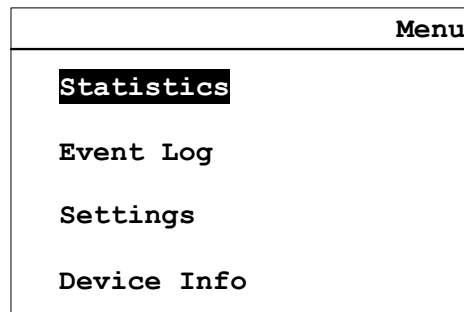

9.4.7 Statistics

Press the "▲" or "▼" button to select the "Statistics" item of main menu and press "↵" button to enter.

Press the "▲" or "▼" button to select "Daily", "Monthly" or "Yearly".

Press the "↵" button to confirm.

Press the "▲" button once to display the previous history record.

Press the "▼" button once to display the next history record.

Press the "ESC" button to return to the main menu.

Statistics	09/11/2013 Day Statistics
Days	Etoday 0.0 KWh
Months	Peak 0 W
Years	Runtime 0 h

9.4.8 Event log

Press the "▲" or "▼" button to select the "Event Log" item of main menu and press the "↵" button to enter.

Press the "▲" or "▼" button to review the event log.

Press the "ESC" button to return to the main menu.

Event Logs		
A	[1] 12/09/2013 08:45	E12 B
	[2] 11/09/2013 17:23	E03
	[3] 10/08/2013 15:23	E43
	[4] 07/07/2013 13:23	E45
	[5] 02/06/2013 12:23	E01

Object	Description
A	Date and time of the fault
B	Error code

9.4.9 Data&Time Setting

Press the "▲" or "▼" button to select the "Setting" item. Press "↵" button to enter. The select the "Basic Setting" and press the "↵" button to enter. Press the "▼" or "▲" button to select the "Date&Time Setting" and press the "↵" button to confirm.

Use the "▲" or "▼" button to set the year, month, day, hour and minute one by one.

Press the "↵" button to confirm.

Press the "ESC" button to return to the "Basic Setting" page.

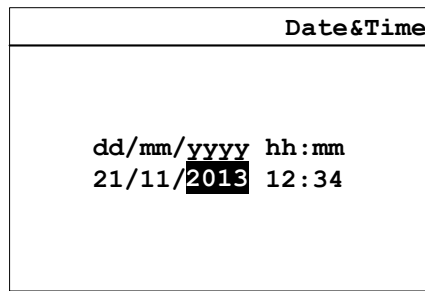

9.4.10 Language setting

Enter the sub-menu "Basic Setting" and press the "▼" or "▲" button to select the "Language Setting" and press the "↵" button to enter.

Use the "▲" or "▼" to choose the language.

Press the "↵" button to confirm.

Press the "ESC" button to return to the "Basic Setting" page.

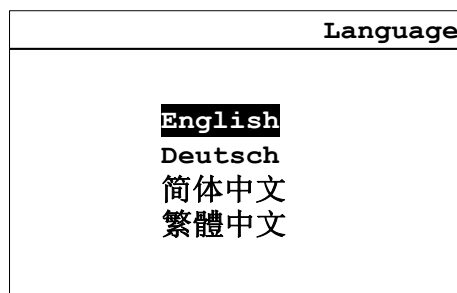

9.4.11 Contrast setting

Enter the sub-menu "Basic Setting" and press the "▼" or "▲" button to select the "Contrast Setting" and press the "↵" button to enter.

Use the "▲" or "▼" to choose the LCD contrast.

Press the "↵" button to save.

Press the "ESC" button to return to the "Basic Setting" page.

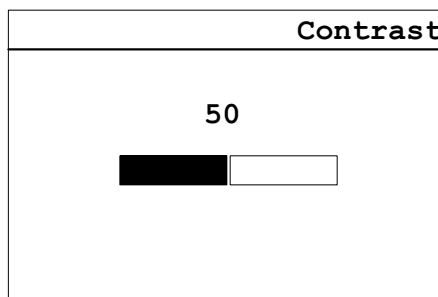

9.4.12 Safety regulations setting

Press the "▲" or "▼" button to enter the "Setting" item of main menu, choose the sub-menu "Advanced Setting" and press the "↵" button to enter, then a pop-up window for password appears. Enter the correct password and press the "↵" button to enter the "advanced setting" sub-menu page. Please get the correct password from the service engineer.

Then select the "Safety Setting" item and press the "↵" button to enter the "safety" page.

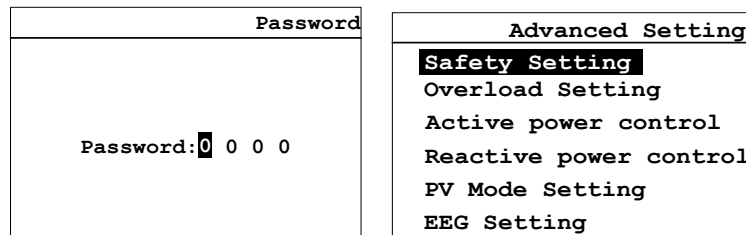

At the "safety" page, use the "▲" or "▼" button to adjust the selected parameter and confirm with the "↵" button, then adjust the next parameters in turn. Parameter adjustment will be finished after the "↵" button has been pressed. Press the "ESC" button to cancel.

Safety		Safety	
Standard:	DE VDE-AR-N 4105	OFF2:	54.50 Hz
OVP2:	265.5 V	OFF1:	53.50 Hz
OVP1:	185.0 V	UFP1:	47.50 Hz
UVP1:	255.0 V	UFP2:	45.50 Hz
UVP2:	180.0 V		
10Min-Mean:	180.5 V		

There are two pages for safety regulation parameters setup. After adjusting the last parameter of the first page, the page will automatically jump to the second page.

NOTICE

The safety of the grid may be influenced due to the improper operating parameters

The default parameters settings comply with the local regulations.

Don't change the values of the monitored operating limits unless the grid operator gives his approval.

9.4.13 Overload setting

Enter the sub-menu "Advanced Setting" and press the "▼" or "▲" button to select the "Overload Setting" and press the "↵" button to enter.

Use the "▲" or "▼" to choose "Enable" or "Disable".

Press the "↵" button to activate the selection.

Press the "ESC" button to return to the "Advanced Setting" page.

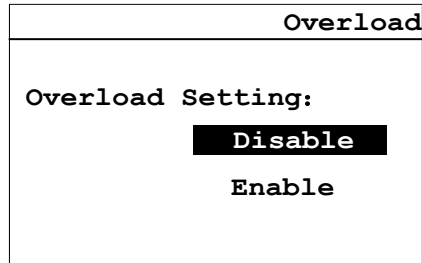

9.4.14 Active power control

Enter the sub-menu "Advanced Setting" and press the "▼" or "▲" button to select the "Active Power Control" and press the "↵" button to enter.

Use the "▲" or "▼" to choose "Enable" or "Disable".

Press the "↵" button to activate the selection.

Press the "ESC" button to return to the "Advanced Setting" page.

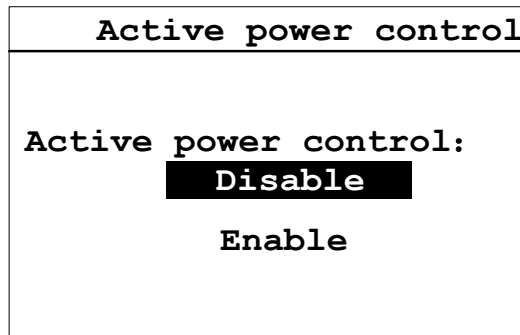

9.4.15 Reactive power control

Enter the "Advanced Setting" menu and press the "▼" or "▲" button to select the "Reactive Power Control" and press the "↵" button to enter the sub menu.

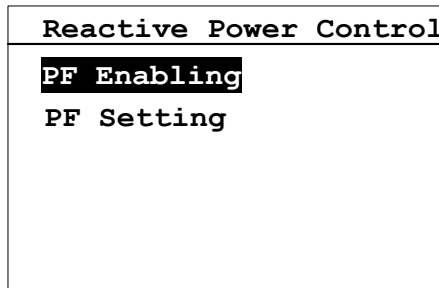

Select the "PF Enabling" item and press "↵" to enter the PF Enabling page. Then press "▲" or "▼" button to disable or enable the function.

Press the "↵" button to enter the reactive power control menu.

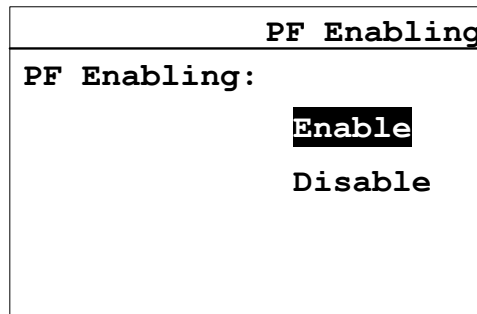

Choose the "PF Setting" item and press the "↵" button to enter.

Use the "▲" or "▼" to choose control mode, the "Customer Mode" or "Fixed PF".

Choose the "Customer Mode" and press "Enter" button to restore the PF parameters to factory setting.

Use the "▲" or "▼" to choose the "Fixed PF" mode and press the "↵" button. Then you can set the PF and phase in turn.

Press the "↵" button to save.

Press the "ESC" button to return to previous menu.

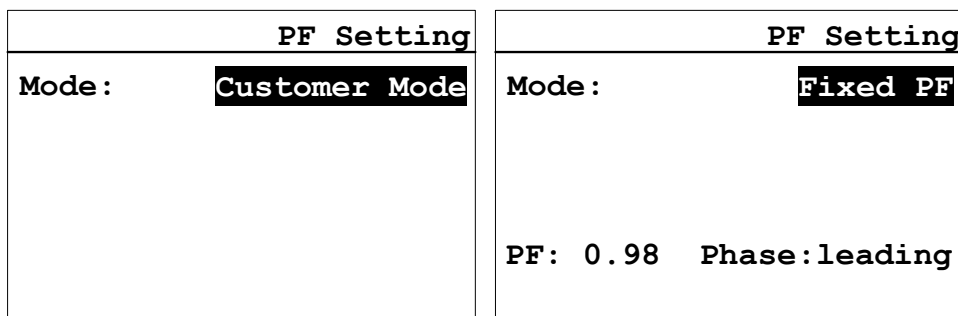

9.4.16 PV Mode setting

Enter the sub-menu "Advanced Setting", and press the "▼" or "▲" button to select

the "PV Mode Setting" and press the "↵" button to enter

Use the "▲" or "▼" button to choose the required PV Mode.

Press the "↵" button to activate the selection.

Press the "ESC" button to return to the "Advanced Setting" page.

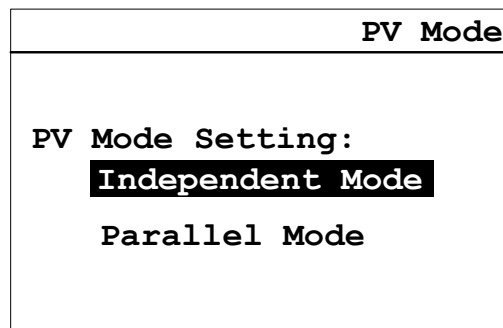

9.4.17 EEG setting

Enter the sub-menu "Advanced Setting", press the "▼" or "▲" button to select the

"EEG Setting" and press the "↵" button to enter.

Use the "▲" or "▼" to choose "Enable" or "Disable".

Press the "↵" button to activate the selection.

Press the "ESC" button to return to the "Advanced Setting" page.

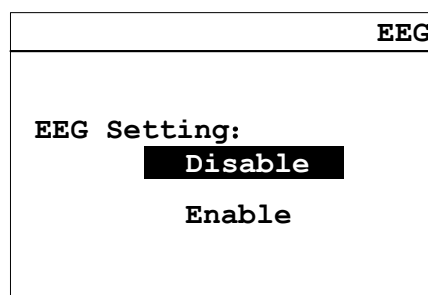

9.4.18 Communication setting

Select the "Communication Setting" item with the "▼" or "▲" button in the "Settings" sub-menu and press "↵" button to enter.

You need wait a second for internal communication complete.

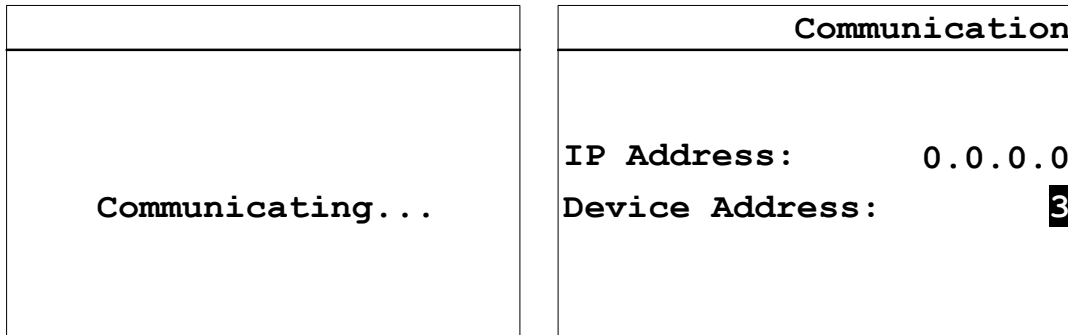

Use the "▲" or "▼" to set the Modbus address.

Press the "↵" button to activate the adjustment.

Press the "ESC" button to return to the previous menu.

If you monitor the inverter via WiFi or Ethernet, the page will show the local IP address that inverter obtain from the router.

9.4.19 Device information

Press the "▼" or "▲" button to select the "Device Info" item of the main menu and press the "↵" button to enter. Press the "ESC" button to return to the main menu.

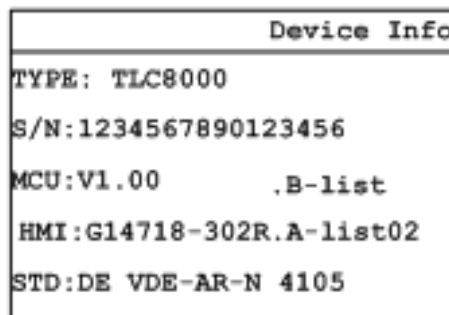

9.4.20 Clear history data

Enter the "Advanced setting" page, then enter the correct password, and press the "↵" button to enter the "Clear Data" page.

The password for entering the "Clear Data" page could be got from the service engineer.

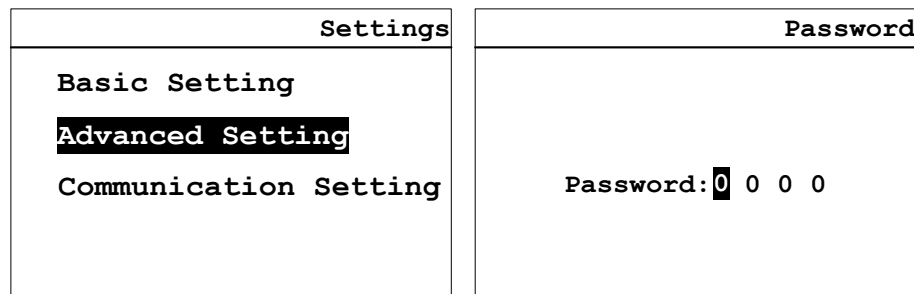

Press the "↵" button to clear the historical data.

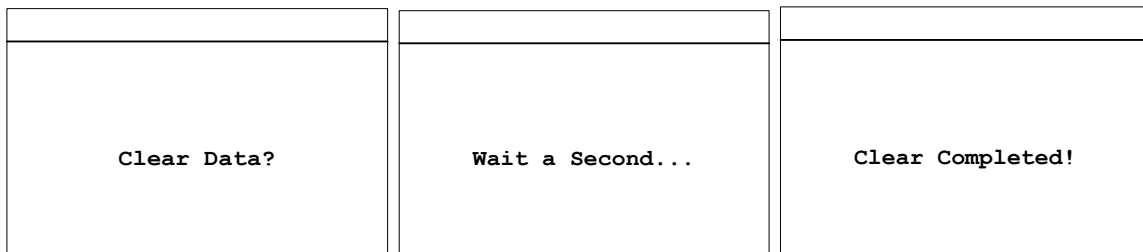

Press the "ESC" button to exit.

10 Technical data

10.1 DC input data

Type	TLC4000	TLC5000	TLC6000
Rated input power (@cosφ=1)	4200 W	5200 W	6300 W
Max. recommended input power	4600W	5700 W	6300W
Max. input voltage/ Rated input voltage	1000V/640V		
MPP voltage range	200~900V		
Full load MPP voltage range	210~900 V	260~900 V	285~900V
Start-up DC input voltage	250V		
Min feed-in DC voltage	180V		
Max. DC input current(input A/ input B)	11A/11A		
I _{sc} PV, absolute max.(input A/ input B)	16.5A/16.5A		
Number of MPP trackers	2		
Strings per MPP tracker	1/1		

Type	TLC8000	TLC10000
Rated input power (@cosφ=1)	8200W	10500W
Max. recommended input power	9000W	10500W
Max. input voltage/ Rated input voltage	1000V / 640V	
MPP voltage range	200~900V	
Full load MPP voltage range	345~900 V	400~900V
Start-up DC input voltage	250V	
Min feed-in DC voltage	180V	
Max. DC input current(input A/ input B)	15A/11A	
I _{sc} PV, absolute max.(input A/ input B)	33A/16.5A	
Number of MPP trackers	2	
Strings per MPP tracker	2/1	

10.2 AC output data

Type	TLC4000	TLC5000	TLC6000
Rated output power	4000 W	5000 W	6000 W
Max. output active power ⁽¹⁾	4400 W	5500 W	6000 W
Max. output apparent power	4400 VA	5500 VA	6000VA
Rated AC voltage	3/N/PE, 220/380V, 230/400V, 240/415V		
Rated AC voltage range (line to line) ⁽²⁾	277 V to 512 V		
Rated power frequency	50 Hz		
AC power frequency ⁽³⁾	50 Hz/ 60 Hz		
Operating range at AC power frequency 50 Hz	45 Hz to 55Hz		
Operating range at AC power frequency 60 Hz	55 Hz to 65Hz		
Rated output current at 220 V	3×6.0A	3×7.5 A	3×9.1A
Rated output current at 230 V	3×5.8 A	3×7.2 A	3×8.7 A
Rated output current at 240 V	3×5.5 A	3×6.9 A	3×8.3 A
Max. continuous output current	3×6.0 A	3×7.5 A	3×9.1 A
Power factor	VDE-AR-N 4105	0.85 ind - 0.85 cap	
	Other safety	>0.97 at 20% load, >0.99 at 100% load	
Inrush current(peak and duration)	28A@252μs	28A@250μs	28A@253μs
Harmonic distortion (THD) at P _{ac,r}	< 3%		
Night-time power loss	<0.6 W		
Standby power loss	<12 W		

Type	TLC8000	TLC10000
Rated output power	8000 W	10000 W
Max. output active power ⁽¹⁾	8800 W	10000 W
Max. output apparent power	8800 VA	10000 VA
Rated AC voltage	3/N/PE, 220/380V, 230/400V, 240/415V	
Rated AC voltage range (line to line) ⁽²⁾	277 V to 512 V	
Rated power frequency	50 Hz	
AC power frequency ⁽³⁾	50 Hz/ 60 Hz	
Operating range at AC power frequency 50 Hz	45 Hz to 55Hz	
Operating range at AC power frequency 60 Hz	55 Hz to 65Hz	
Rated output current at 220 V	3×12.1 A	3×15.2 A
Rated output current at 230 V	3×11.6 A	3×14.5 A
Rated output current at 240 V	3×11.1 A	3×13.9 A
Max. continuous output current	3×12.1 A	3×15.2 A
Power factor	VDE-AR-N 4105	0.85ind - 0.85cap
	Other safety	>0.97 at 20% load, >0.99 at 100% load
Inrush current(peak and duration)	41A@252μs	41A@250μs
Harmonic distortion (THD) at P _{ac,r}	< 3%	
Night-time power loss	<0.6 W	
Standby power loss	<12 W	

(1) Maximum 10% AC overload can be activated by settings on LCD (refer to section 9.4.13) , Please make sure that it is compliant with local regulations and DNO's requirements before enabling. .

(2) The AC voltage range depends on the local safety standards and rules.

(3) The AC frequency range depends on the local safety standards and rules.

10.3 General data

Type	TLC4000~TLC6000	TLC8000~TLC10000
Net weight	21 KG	24 KG
DimensionsL×W×D	405×498×222 mm	405×498×255 mm
Mounting environment	Indoor and Outdoor	
Mounting recommendation	Wall bracket	
Operating temperature range	-25...+60°C	
Max. permissible value for relative humidity (non-condensing)	100%	
Max. operating altitude above mean sea level	2000m	
Ingress protection	IP65 according to IEC60529	
Climatic category	4K4H	
Protection class	I (in accordance with IEC 62103)	
Overvoltage category	DC input: II, AC output: III	
Topology	Transformerless	
Feed-in phases	3	
Cooling concept	Convection	
Noise	<40 dB(A) @ 1m	<45 dB(A) @ 1m
Display	240×160 pixels, LCD	
Communication interfaces	RS485/USB/ Ethernet (optional) /wifi (optional)	
Standard warranty	5 years	

10.4 Safety regulations

Type	TLC4000~TLC10000
Internal overvoltage protection	Integrated
DC insulation monitoring	Integrated
DC feed-in monitoring	Integrated
Grid monitoring	Integrated
DC isolator	Optional
DC reverse polarity protection / AC short-circuit current capability	Integrated
Residual current monitoring	Integrated
Islanding protection	Integrated (Three-phase monitoring)
EMC immunity	EN61000-6-1, EN61000-6-2
EMC emission	EN61000-6-3, EN61000-6-4
Utility interference	EN61000-3-2, EN61000-3-3
Overvoltage category (according to IEC 60664-1)	II (DC), III (AC)



If you choose the safety standard VDE-AR-N 4105, please refer to information below. If a central NS protection device is used for power generation system, then the value of the rise-in-voltage protection $U > 1.1U_n$ presented in the integrated NS protection can be changed, but need password.

10.5 Efficiency

The operating efficiency is shown for the three input voltages (V_{mppmax} , $V_{dc,r}$ and V_{mppmin}) graphically. In all cases the efficiency refers to the standardized power output ($P_{ac}/P_{ac,r}$). (According to EN 50524 (VDE 0126-13): 2008-10, cl. 4.5.3).

Notes: Values are based on rated grid voltage, $\cos(\phi) = 1$ and an ambient temperature of 25 °C.

Efficiency curve TLC4000

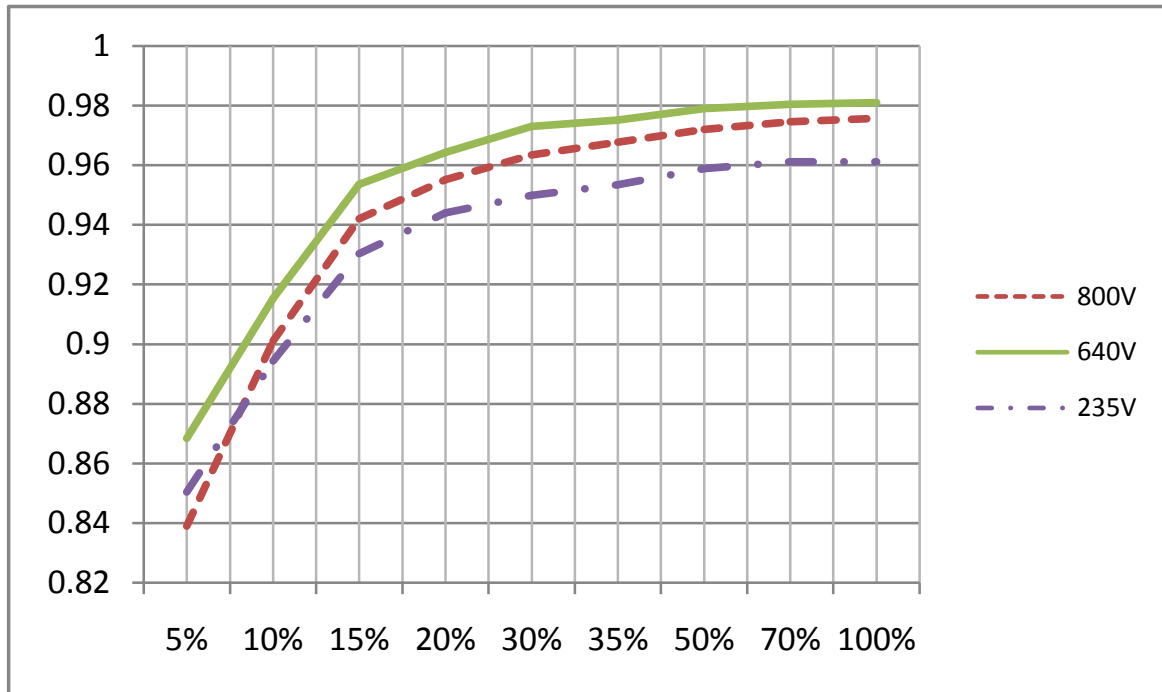

Max. efficiency, η max	98.09 %
European weighted efficiency, η EU	96.99 %

Efficiency curve TLC5000

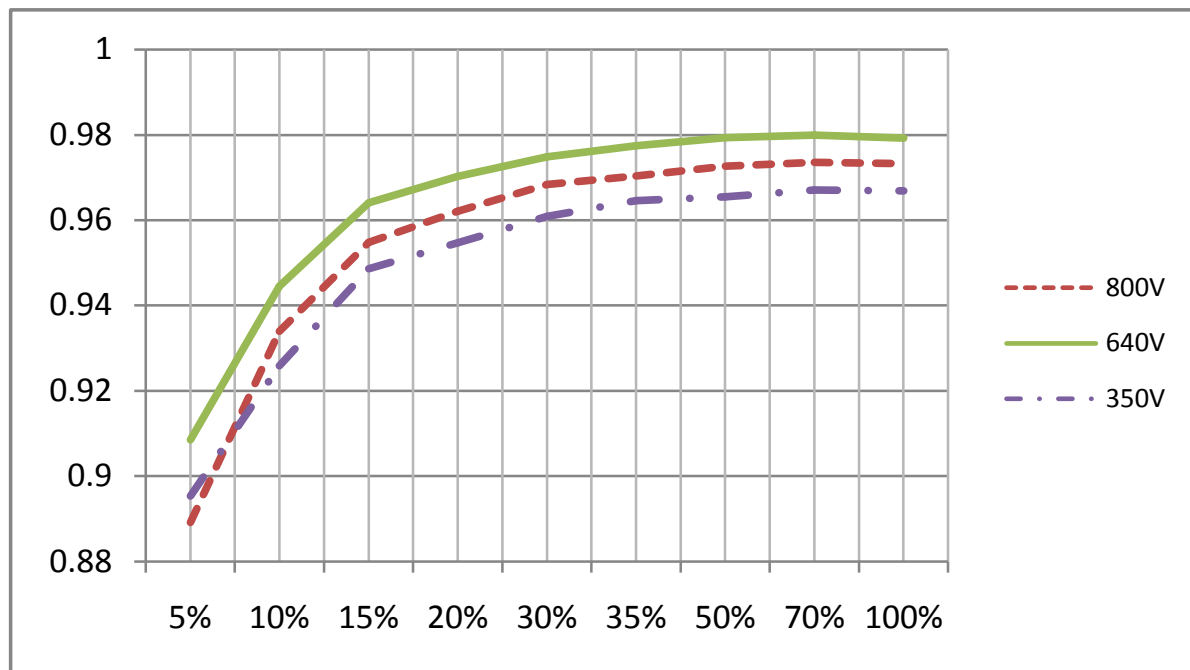

Max. efficiency, η max	98.04 %
European weighted efficiency, η EU	97.12 %

Efficiency curve TLC6000

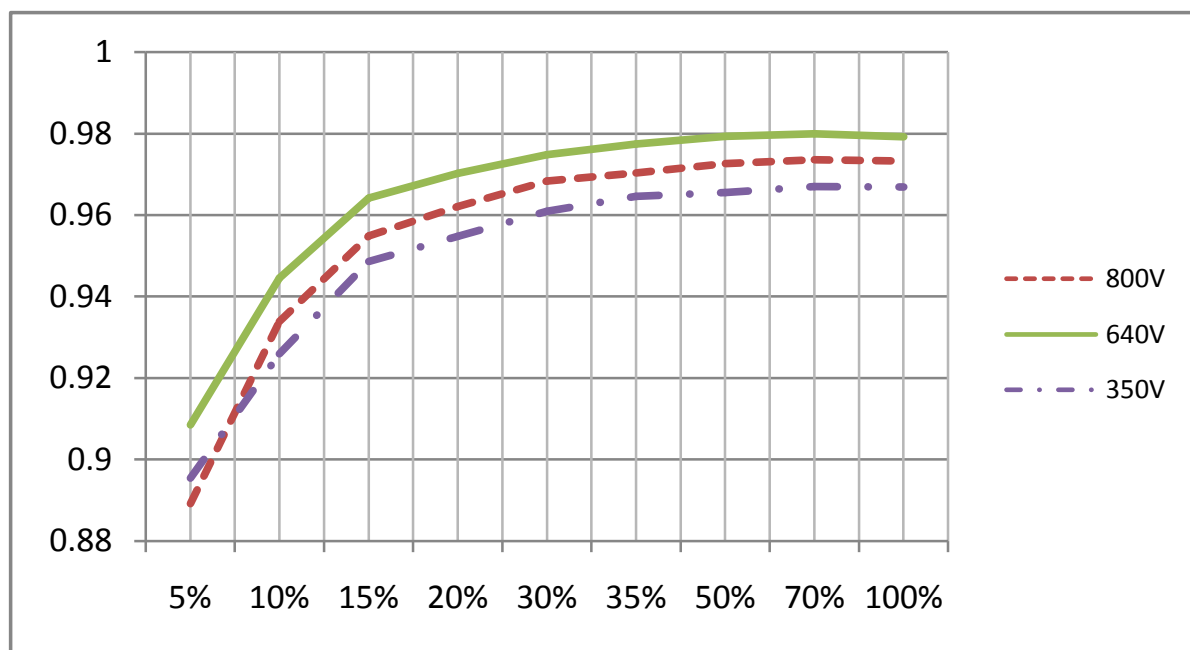

Max. efficiency, η max	97.99 %
European weighted efficiency, η EU	97.34 %

Efficiency curve TLC8000

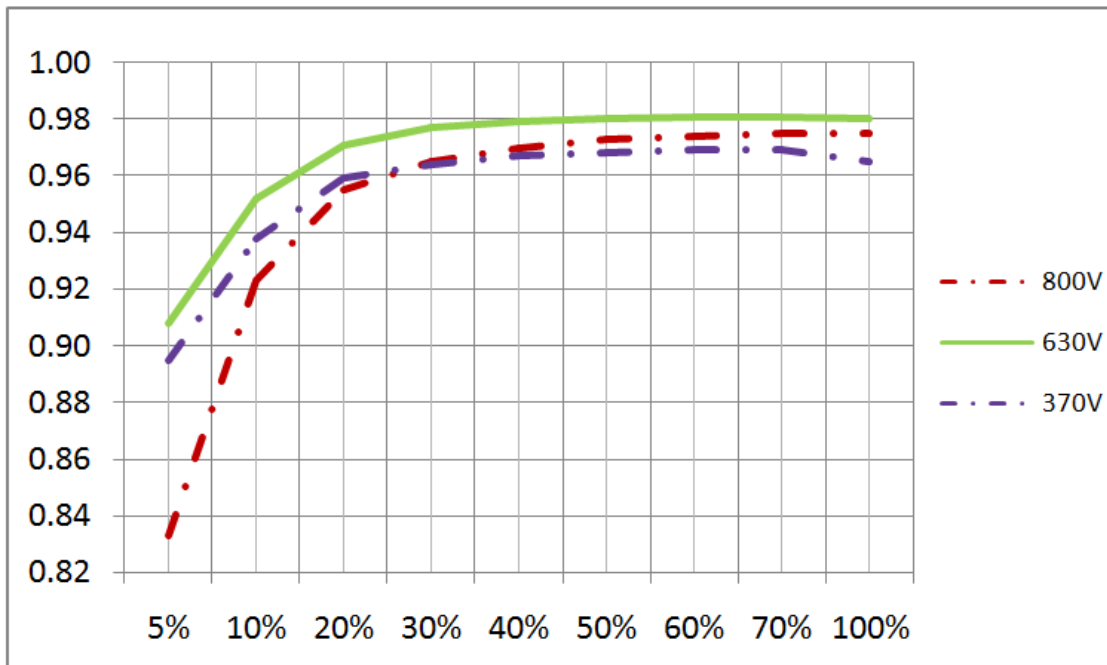

Max. efficiency, η_{max}	98.1%
European weighted efficiency, η_{EU}	97.5%

Efficiency curve TLC10000

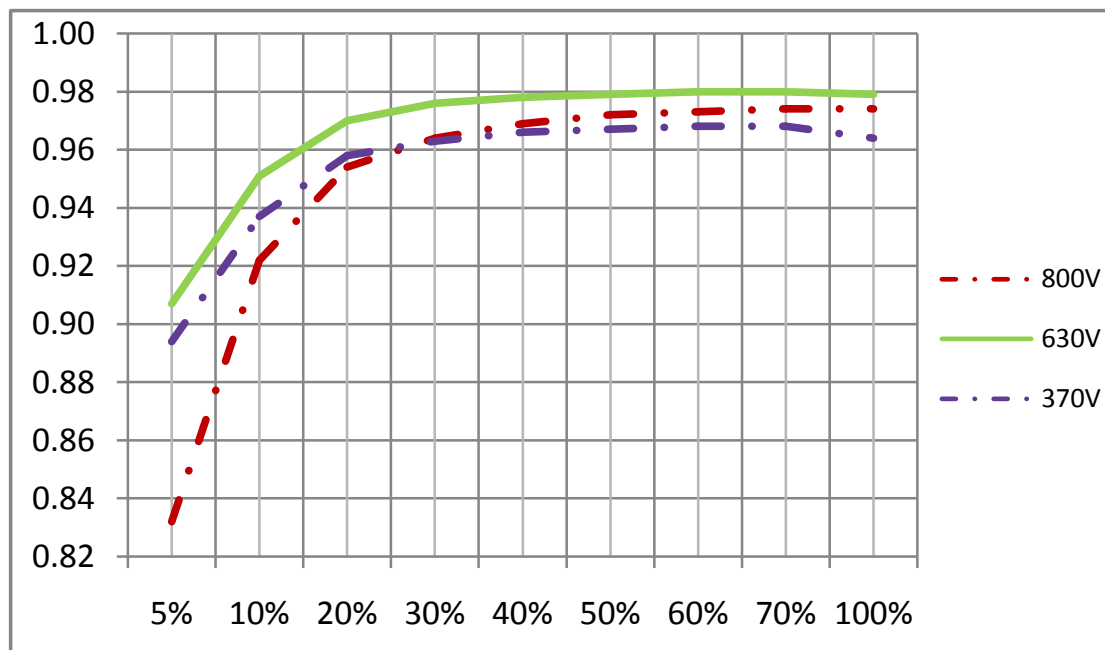

Max. efficiency, η_{max}	98.1%
European weighted efficiency, η_{EU}	97.6%

10.6 Power reduction

In order to ensure inverter operation under safe conditions, the device may automatically decrease power output.

Power reduction depends on many operating parameters including ambient temperature, input voltage, grid voltage, grid frequency and power available from the PV modules. This device can decrease power output during certain periods of the day according to these parameters.

Notes: Values based on rated grid voltage and $\cos(\phi) = 1$.

Power reduction with increased ambient temperature (TLC4000)

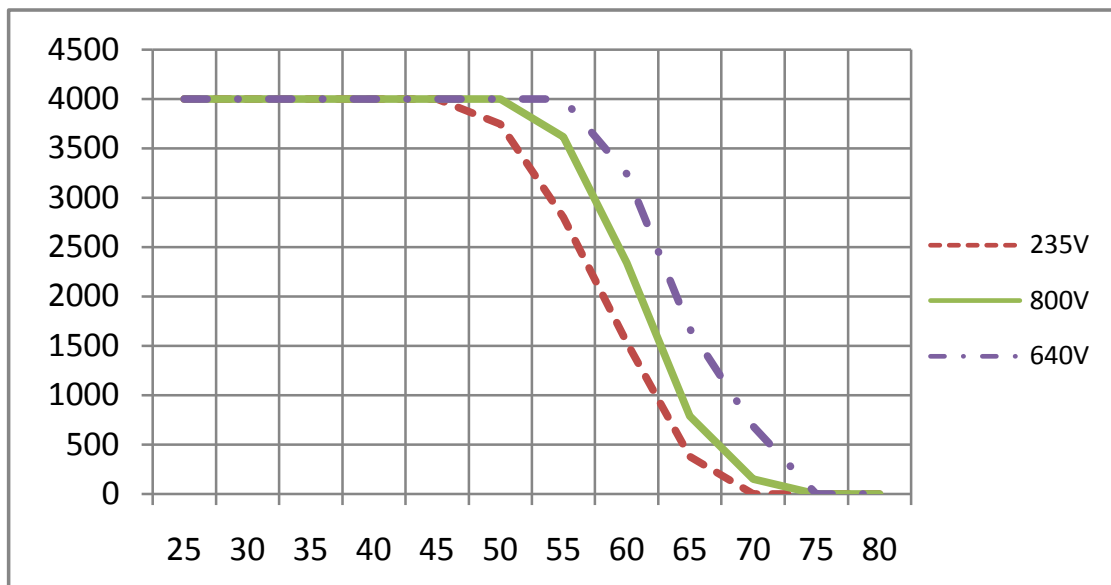

Power reduction with increased ambient temperature (TLC5000)

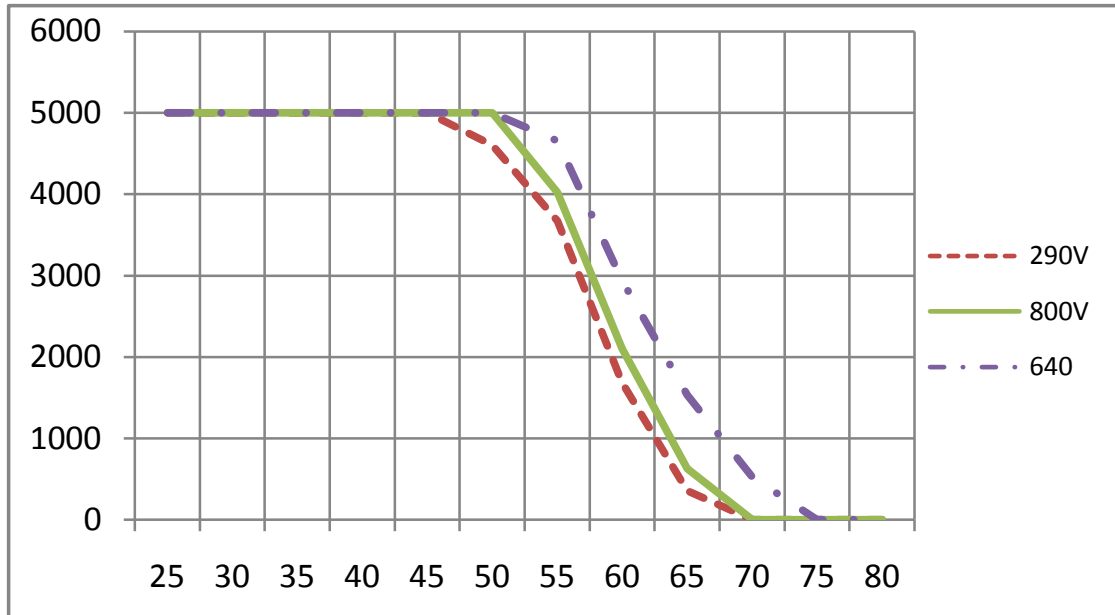

Power reduction with increased ambient temperature (TLC6000)

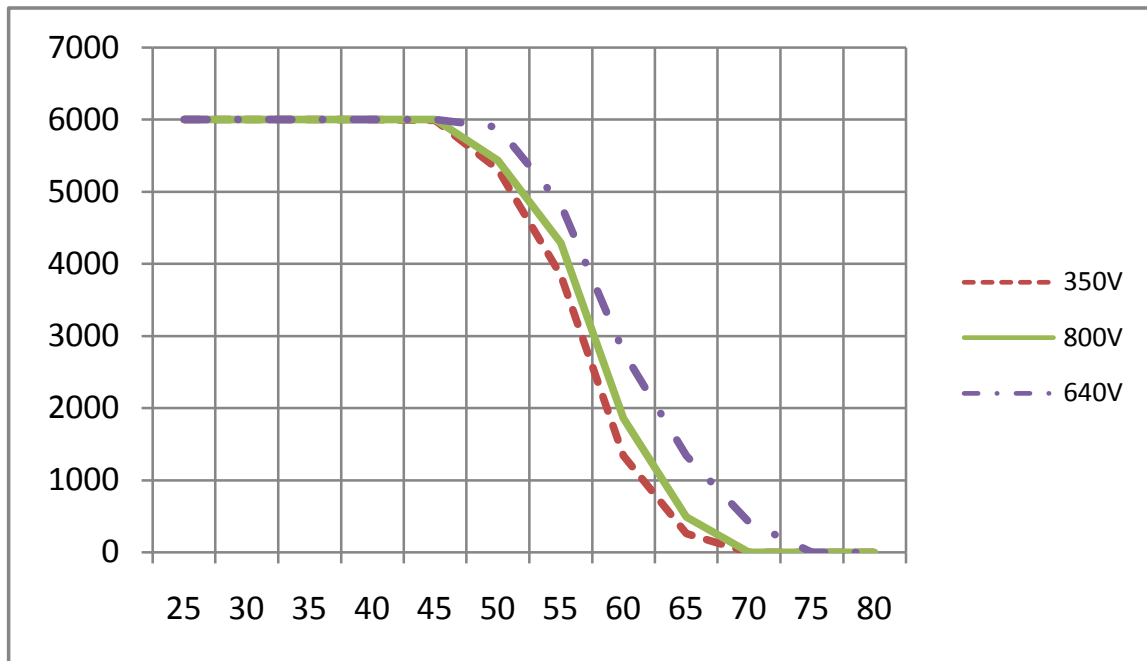

Power reduction with increased ambient temperature (TLC8000)

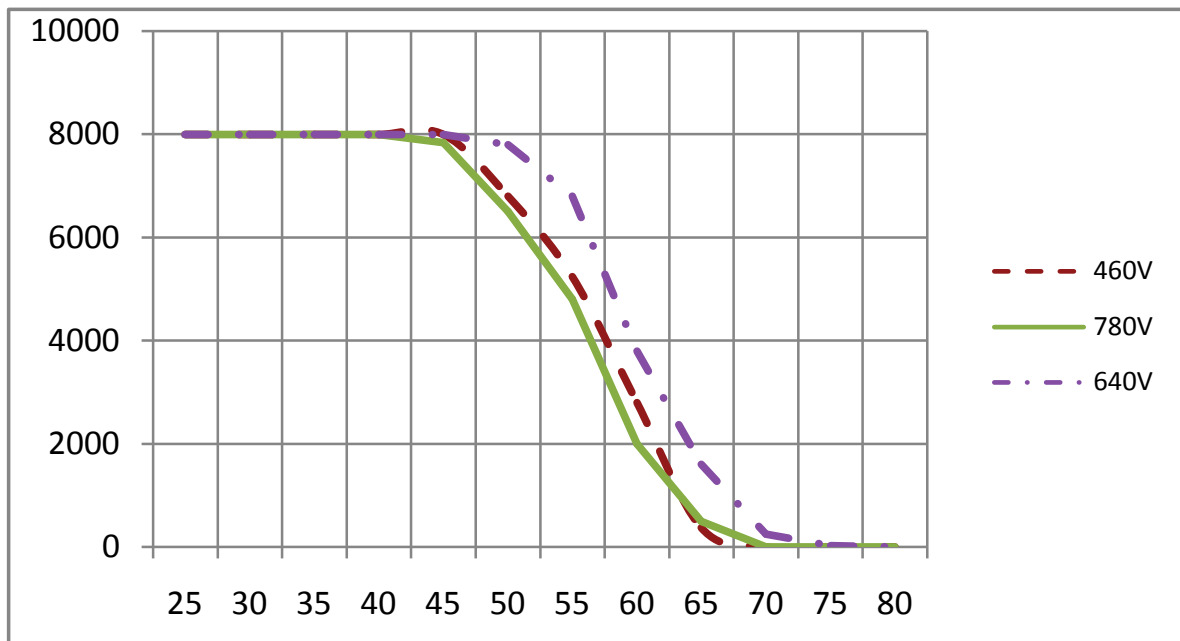

Power reduction with increased ambient temperature (TLC10000)

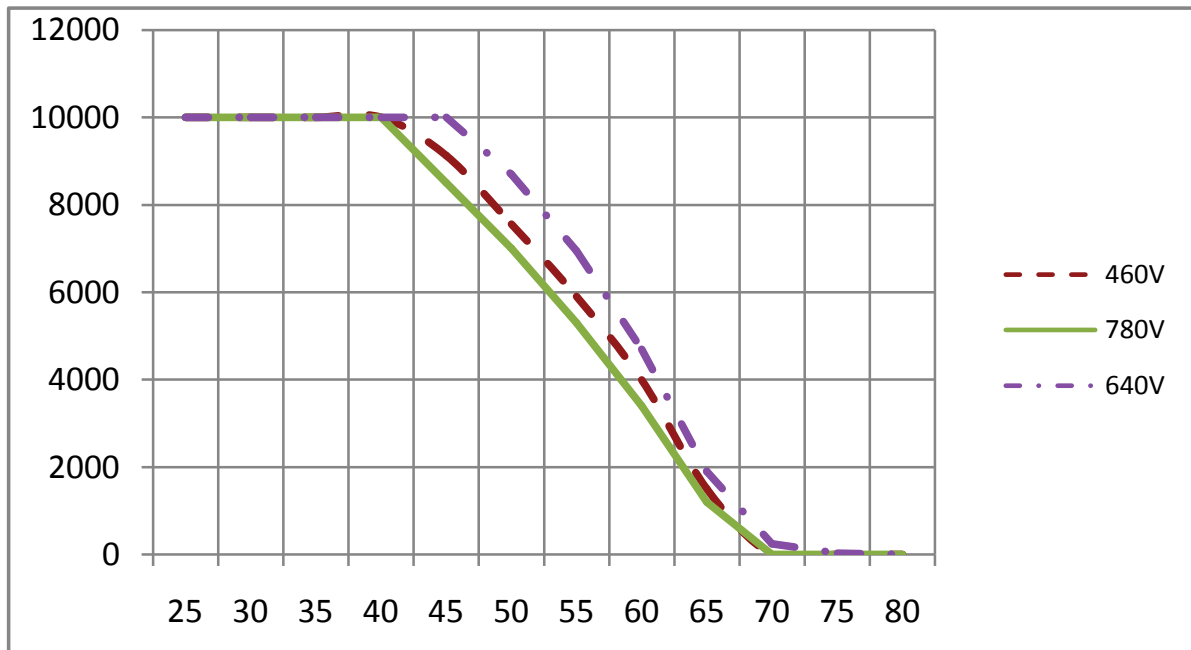

11 Troubleshooting

When the PV power plant does not operate normally, fault information will be show up on the display and the red LED will be lit at the same time.

We recommend the following actions for quick troubleshooting.

The corresponding causes are described in section 9.3 “Display messages”.

Object	Error code	Corrective measures
Resumable Fault	33	<ul style="list-style-type: none"> •Check the grid frequency and observe how often major fluctuations occur. <p>If this fault is caused by frequent fluctuations, try to modify the operating parameters after informing the utility provider first.</p>
	34	<ul style="list-style-type: none"> •Check the grid voltage and grid connection on the inverter. •Check the grid voltage at the point of connection of the inverter. <p>If the grid voltage is outside the permitted range due to local grid conditions, try to modify the values of the monitored operating limits after informing the electric utility company first.</p> <p>If the grid voltage lies within the permitted range and this fault still occurs, contact the service.</p>
	35	<ul style="list-style-type: none"> •Check the fuse and the triggering of AC circuit breaker in the distribution box. •Check grid voltage, grid usability. •Check AC cable, grid connection on the inverter. <p>If this fault is still being shown, contact the service.</p>
	36	<ul style="list-style-type: none"> •Make sure the ground connection of the inverter is reliable. •Make a visual inspection of all PV cables and modules. <p>If this fault is still shown, contact the service.</p>
	37	<ul style="list-style-type: none"> •Check the open-circuit voltages of the PV strings, make sure it is lower than the Max. DC input voltage of the inverter. <p>If the input voltage lies within the permitted range and the fault still occurs, contact the service.</p>

Resumable Fault	38	<ul style="list-style-type: none"> •Check the PV generator's insulation to ground, make sure that the insulation resistance to earth is greater than 1MΩ; Otherwise, make a visual inspection of all PV cables and modules. •Make sure the ground connection of the inverter is reliable. <p>If this fault occurs often, contact the service.</p>
	40	<ul style="list-style-type: none"> •Check whether the airflow to the heat sink is obstructed. •Check whether the ambient temperature around the inverter is too high.
	41, 42 43, 44	<ul style="list-style-type: none"> •Disconnect the inverter from the grid and the PV generator, reconnect them after 3 minutes. <p>If this fault is still being shown, contact the service.</p>
	46	<ul style="list-style-type: none"> •Check the open-circuit voltages of the strings, make sure it is lower than the Max. DC input voltage of the inverter; <p>If the input voltage lies within the permitted range, and the fault still occurs, maybe the internal circuit has broken, contact the service.</p>
Permanent Fault	1,2,3,4,8, 9,10, 11,39	<p>Disconnect the inverter from the grid and the PV generator, reconnect them after 3 minutes. If this fault is still being shown, contact the service.</p>

12 Maintenance

Normally, the inverter needs no maintenance or calibration. Regularly inspect the inverter and the cables for visible damage. Disconnect the inverter from all power sources before cleaning. Clean the housing, cover and display with a soft cloth. Ensure the heatsink at the rear of the inverter cover is not covered.

12.1 Cleaning the contacts of the DC-switch

Clean the contacts of the DC-switch once per year. Perform cleaning by cycling the switch to “1” and “0” positions 5 times. The DC-switch is located at the lower left of the housing.

12.2 Cleaning the heat sink

CAUTION

Risk injury due to hot heat sink

- The heat sink may exceed 70 °C during operation. Do not touch the heatsink during operation.
- Wait approx. 30 minutes before cleaning until the heatsink has cooled down.

Clean the heat sink with pressurized air or a soft brush. Do not use aggressive chemicals, cleaning solvents or strong detergents.

For proper function and long service life, ensure free air circulation around the heatsink.

13 Recycling and disposal

Dispose of the packaging and replaced parts according to the rules at the installation site where the device is installed.

Do not dispose the inverter with normal domestic waste.



WEEE designation

Do not dispose of the product together with the household waste but in accordance with the disposal regulations for electronic waste applicable at the installation site.

14 Warranty

The factory warranty card is enclosed with the package, please keep well the factory warranty card. Warranty terms and conditions can be downloaded at www.zeversolar.com/service/warranty/ if required. When the customer needs warranty service during the warranty period, the customer must provide a copy of the invoice, factory warranty card, and ensure the type label of the inverter is legible. If these conditions are not met, Zeversolar has the right to refuse to provide with the relevant warranty service.

15 Contact

If you have any technical problems concerning our products, please contact Zeversolar service. We require the following information in order to provide you with the necessary assistance:

- Inverter device type
- Inverter serial number
- Type and number of connected PV modules
- Error code
- Mounting location
- Warranty card

Zeversolar Service Contact

Our regional service contact information can be found at :

<https://www.zeversolar.com/service/customer-interaction-center/>

Jiangsu Zeversolar New Energy Co., Ltd.

Tel.: +86 512 6937 0998

Fax: +86 512 6937 3159

Web: www.zeversolar.com

Factory add.: No.588 Gangxing Road, Yangzhong Jiangsu, China

Headquarters add.: Building 9, No.198 Xiangyang Road, Suzhou 215011, China

540-00115-01

REV	DATE
01	2016/04/05